

台灣電力公司 綜合研究所

TPRI



TAIWAN POWER
RESEARCH
INSTITUTE

115年度

目錄(Contents)

經營者 Management Profile	1
人力 Human Resources	2
組織 Organization	3
經營策略 Business Strategy	4
研究發展 Research & Development	
⚡ 研究發展企劃室 R & D Planning Office	5
⚡ 電力研究室 Electric Power Research Lab	6
⚡ 資訊與通信研究室 Information & Communication Technology Research Lab	9
⚡ 能源研究室 Energy Research Lab	16
⚡ 負載管理研究室 Load Management Research Lab	22
⚡ 化學與環境研究室 Chemistry and Environmental Research Lab	26
⚡ 高壓研究室 High Voltage Research Lab	31
⚡ 電力經濟與社會研究室 Electricity Economics & Social Research Office	34
試驗業務 Testing Services	
⚡ 電力設備試驗組 Power Apparatus Testing Section	39
⚡ 儀器組 Measuring Instruments Section	40
⚡ 電表組 Electricity Metering Section	41
⚡ 高壓試驗組 High Voltage Testing Section	42
⚡ 化檢組 Chemical Testing Section	43
⚡ 油煤試驗組 Oil & Coal Testing Section	44
展望 Future Outlook	45

經營者

Management Profile



副所長蒲冠志 (代理所長)

Deputy General Manager (Acting General Manager)
Pu, Guan-Chih



副所長張志聲

Deputy General Manager
Chang, Chih-Sheng



副所長王金墩

Deputy General Manager
Wang, Chin-Tun

人力 Human Resources

● 人員 Staff Members

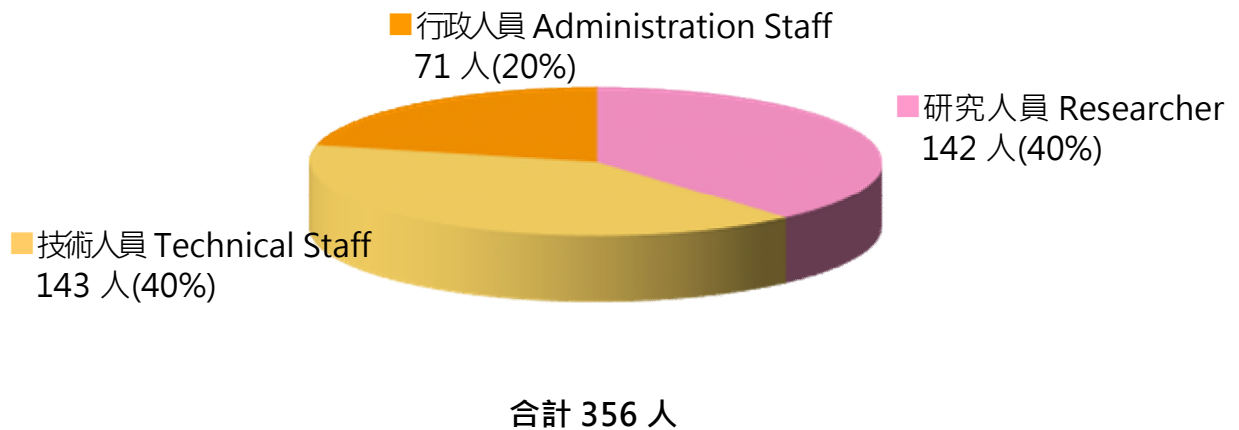

● 學歷 Educational Background

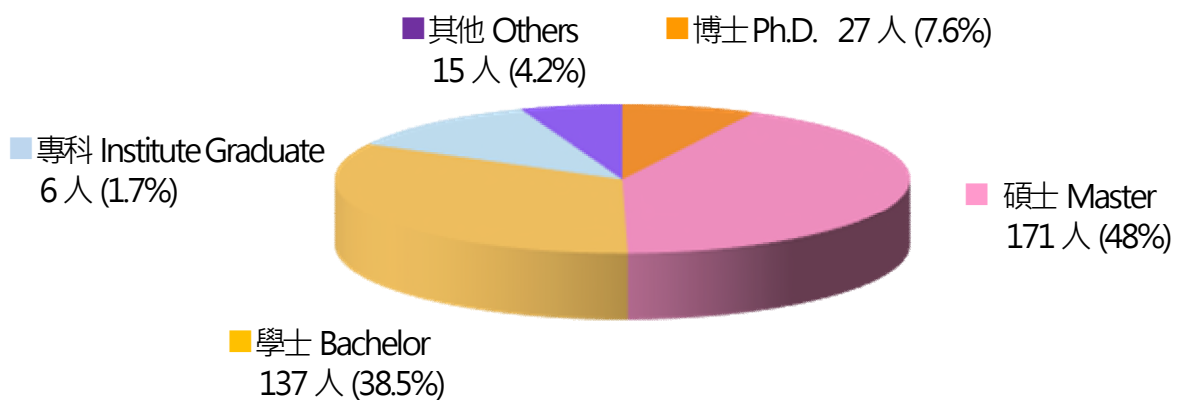

● 專長 Specialty

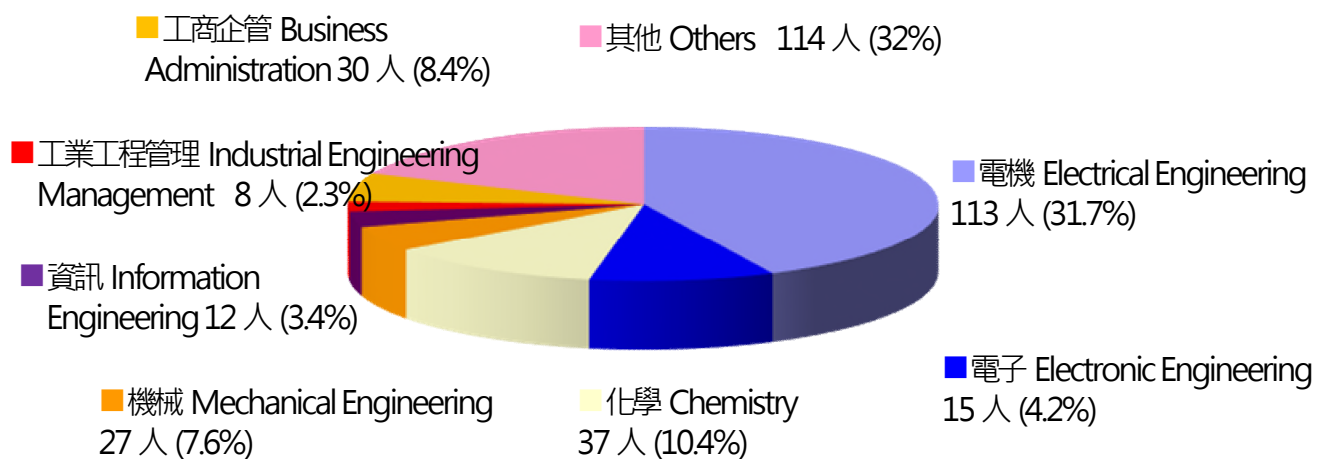

組織 Organization



經營策略

本研究單位以核心技術與專業能力為基礎，在遵循公司整體發展目標與策略方向的前提下，致力於建構公司短、中、長程研究規劃與試驗技術之創新應用。透過核心技術之建立、國際合作交流及新興科技的引進，持續提升公司經營績效與降低營運成本，致力使台電成為引領電力產業發展的標竿企業。

因應政府推動能源轉型與淨零排放等政策目標，並支援「5+2 產業創新計畫」及其後續「六大核心戰略產業」、「五大信賴產業」推動方案等政策所需電力，本公司除確保穩定供電外，亦積極投入再生能源開發，推動電網擴充與升級。同時，結合 5G、人工智慧與大數據等數位科技，擴大智慧電網之應用範疇，落實數位轉型與科技創新。

為加速回應淨零挑戰下之前瞻技術發展需求，自 114 年度起研發規劃採「50%-50%研發投資組合」發展策略，即 50%資源用以支援公司營運需求，50%投入前瞻技術研發，以期達成零碳與永續發展目標。

Business Strategy

This research unit, grounded in core technologies and professional expertise, operates in alignment with the Company's overarching development objectives and strategic direction. It is dedicated to formulating short-, medium-, and long-term research plans and advancing innovative applications of experimental technologies. By strengthening core competencies, fostering international cooperation and exchange, and adopting emerging technologies, the unit continuously enhances operational performance and reduces operating costs, with the aim of positioning Taiwan Power Company (Taipower) as a benchmark enterprise leading the development of the power industry.

In response to government policies promoting energy transition and net-zero emissions, and to ensure a reliable electricity supply that supports national economic initiatives—including the “5+2 Industrial Innovation Program” and its subsequent “Six Core Strategic Industries” and “Five Trusted Industries” promotion plans—the Company is not only committed to maintaining a stable power supply, but also actively engaged in renewable energy development and in the expansion and upgrading of the power grid. In parallel, the Company leverages digital technologies such as 5G, artificial intelligence, and big data to broaden the scope of smart grid applications, thereby advancing digital transformation and technological innovation.

To accelerate the development of forward-looking technologies in the face of the net-zero challenge, the Company has adopted a “50–50 R&D investment portfolio” strategy starting in fiscal year 2025. Under this framework, 50% of research and development resources are allocated to supporting operational needs, while the remaining 50% are directed toward the development of frontier technologies, with the overarching goal of achieving carbon neutrality and sustainable development.

研究發展 Research & Development

⚡ 研究發展企劃室 R&D Planning Office

• 前瞻策略規劃 創新研發治理

Technology foresight strategy, Innovative R&D governance

擔任所長室幕僚，推動本所研發試驗相關活動，實踐研發管理價值鏈，精準研發策略布局，俾支持台電公司達成能源轉型及創新成長目標。

Serving as a staff officer to the Director's Office, responsible for advancing the Institute's research, development, and testing activities, implementing the R&D management value chain, and ensuring precise strategic positioning of research and development efforts — all in support of Taiwan Power Company's goals of energy transition and innovative growth.

• 四大核心任務

Four Core Missions

1. 推動創新治理及前瞻電力技術預測
Advancing Innovative Governance and Foresight-Based Power Technology Forecasting
2. 綜理台電公司研發管理流程
Overseeing the Comprehensive Management of Taiwan Power Company's R&D Processes
3. 促進國際電業交流與合作
Fostering International Utility Exchange and Cooperation
4. 內外部利害關係人溝通與研發成果推廣
Internal and External Stakeholder Engagement and Dissemination of R&D Outcomes



研發企劃架構圖 R&D Planning Framework

• **電力系統研究組**

Power System Analysis and Improvement Techniques

1. 再生能源及儲能設備之虛擬慣量提供 (Provision of virtual inertia through renewable energy and energy storage devices)
2. 飛輪及同步調相機實現慣量調節 (Implementation of inertia regulation using flywheels and synchronous phase adjusters)
3. 智慧型電網規劃與推動 (Planning and Development of Smart Grid)
4. 電力系統有關電力潮流、故障電流、電壓穩定度、動態穩定度、暫態穩定度、保護協調、虛擬慣量等分析技術 (Power System Analysis - Power Flow, Fault Current, Voltage Stability, Dynamic Stability, Transient Stability, Virtual inertia, and Protection Coordination)
5. 電力系統特性監測分析及監測系統之網路應用技術 (Power System Monitoring and Internet Applications)
6. 電力系統調度運轉技術 (Power System Operation Techniques)
7. 電力系統驗證與測試模擬 (Power System Simulation Center-Large Network System Study, Control System Validation, and System Protection Scheme Study)
8. 彈性交流輸電系統之輸電容量彈性調度應用技術 (Application of Flexible AC Transmission System Techniques to Increase Transmission Capacity)
9. 能源管理系統與系統分析 (Energy Management System and System Analysis)
10. 再生能源高滲透率之電力系統穩定度分析 (Stability Analysis of Power System with High Renewable Energy Permeability)
11. 發電機組模型參數定期量測與確認 (Technology Platforms for Power System Testing and Reviewing Plans for the Parameters of Generator Models)
12. 虛擬同步機模型開發與參數研究 (Development and Parameter Research of Virtual Synchronous Generator Model)



發電機參數測試驗證

Testing and Verification for the Parameter of Generator Models

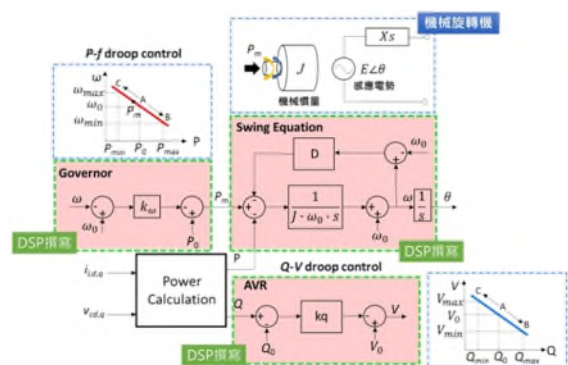

基礎虛擬同步機控制模型

Basic Virtual Synchronous Generator Control Model

- 電力電子應用研究組

Power Electronics Application

- 針對基於電力電子電源設備進行探討，標的包含再生能源變流器、儲能系統電力轉換系統、靜態同步補償器、固態變壓器、直交流系統等(Focusing on Inverter Based Resource research, including inverter of renewable energy, power conversion system of energy storage system, STATCOM, solid-state transformer and hybrid AC/DC system)
- 由設備技術面、併網響應面、以及制度面執行相關研究(Research topics cover equipment characteristic, interconnecting response and policy)
 - 設備技術面：硬體架構、控制架構、控制參數等(Equipment Characteristic: hardware, control and parameter)
 - 併網響應面：適用範疇、對系統運轉與品質影響、系統模擬、電力閉迴路測試(Interconnecting Response: application, performance, power system simulation and hardware in the loop testing)
 - 制度面：國際規範、併網要求、設備併網功能驗證(Policy: international standard, interconnecting requirement, functionality verification)
- 電力諧波、電壓閃爍及不平衡現象等之監測、分析及改善技術 (Monitoring, Analysis and Mitigation of Power System Harmonic, Voltage Flicker, and System Unbalance Problems)
- 高科技產業供電品質問題，如電壓驟降等之監測、分析與改善技術 (Monitoring, Analysis, and Mitigate the Hi-tech Industrial Park Voltage Dip Problems)

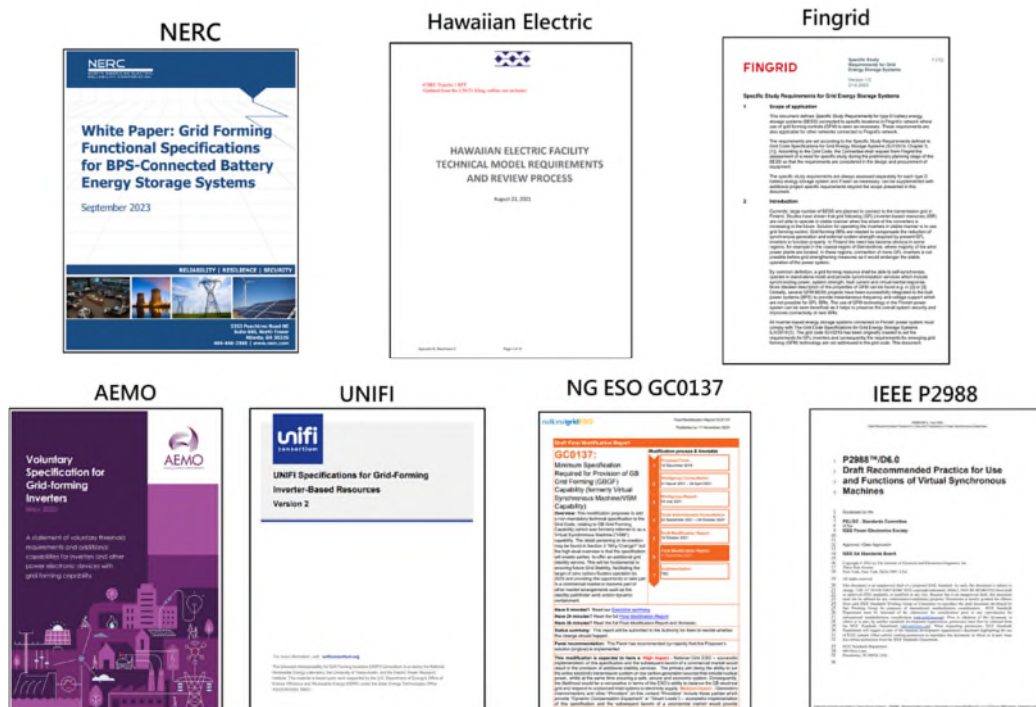

構網型變流器之規範研析

Grid Forming Inverter Standard Analyzation

- 分散式電源應用研究組

Distributed Power Application and Analysis Technology

1. 微電網驗證場域各式測試情境之參數調校研析 (Parameter Tuning Analysis for Various Test Scenarios in Microgrid Validation Sites)
2. 交直流複合微電網系統開發設計 (Development and Design of AC-DC Composite Microgrid System)
3. 直流微電網應用之關鍵技術探討 (Discussion on the key technologies of DC Micro-grid application)
4. 微電網不斷電與黑啟動技術分析與應用 (Analysis and application of microgrid uninterruptible power supply and black start technology)
5. 微電網儲能設備自主調控技術 (Microgrid energy storage equipment self-regulation technology)
6. 分散式電源最大功率追蹤控制技術 (Distributed power supply maximum power tracking control technology)
7. 交流家電負載改以直流供電之技術探討 (Technical discussion on converting AC household electrical loads to DC power supply)
8. 輸配電系統狀態估測技術 (Power transmission and distribution system condition estimation technology)

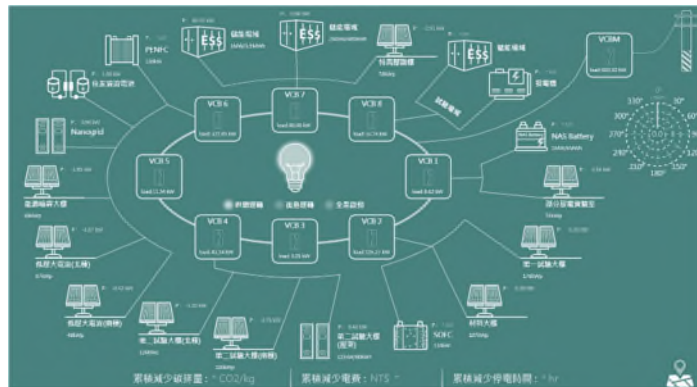

微電網驗證場域測試

Microgrid verification field test

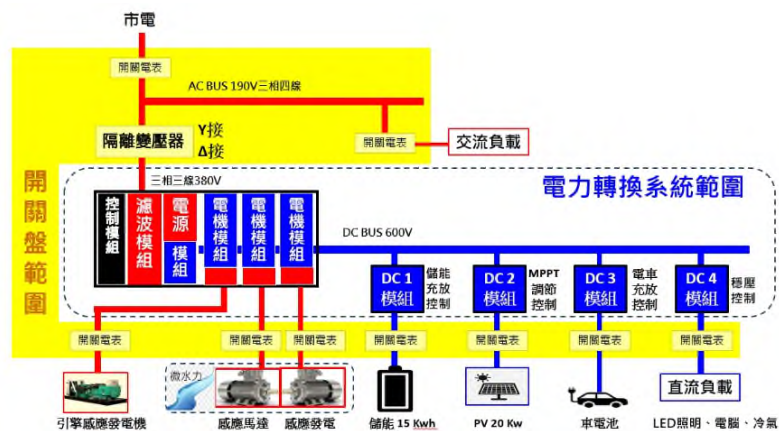

交直流複合微電網系統開發

AC/DC hybrid microgrid system development

• 智網標準推動研究組

Smart Grid Standards Promotion and Research Group

1. 智慧電網國際資通訊標準研究評估及策略規劃
Smart Grid International Information and Communication Standards Study, Evaluation, and Strategic Planning.
2. 智慧電網導入國際標準之推動
Promoting the implementation of international standards for smart grid.
3. IEC 61850 互操作性測試、功能性測試、效能測試研究
Research for IEC 61850 Interoperability testing, Functional testing, and Performance testing.
4. IEC 61850 標準技術開發與實作
Technological development and implementation based on IEC 61850 standards.
5. 資安攻防平台開發與研究
Development and Research of Cybersecurity Attack and Defense Platforms.

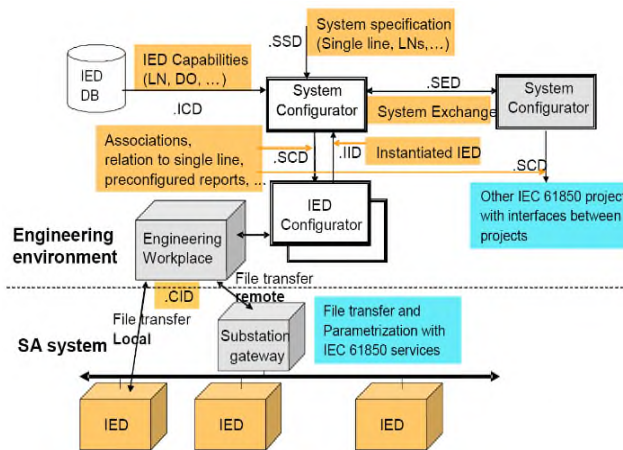

IEC 61850 資料交換研究
資料來源：IEC 61850-6

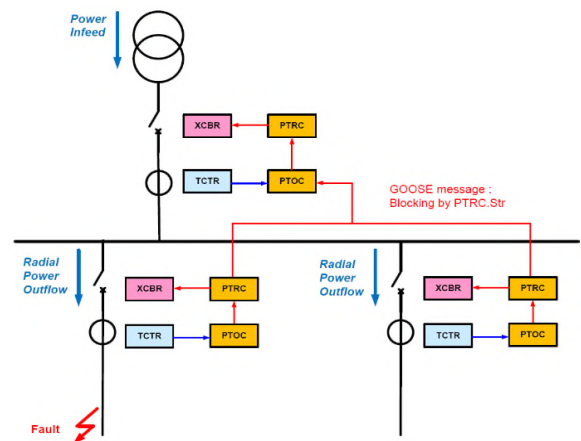

IEC 61850 於變電所應用情境研析
資料來源：IEC TR 61850-7-500



台電公司 IEC 61850 互操作性試驗
資料來源：綜研所資通室



台電公司 IEC 61850 互操作性試驗
資料來源：綜研所資通室

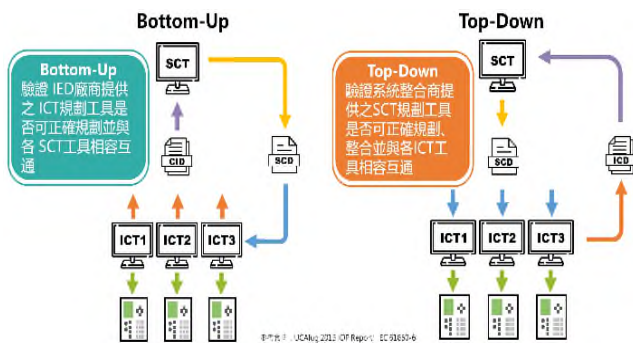

ICT 與 SCT 整合技術研究
資料來源:UCAlug 2013 IOP Report; IEC 61850-6

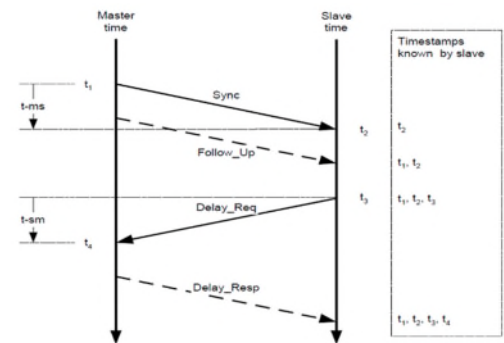

PTP 精度測試
資料來源:IEEE Std. 1588, Rev. 2, 2008

- 資通訊技術組
ICT Techniques Group

1. XR 技術導入二次變電所訓練研究
Research on the Application of XR Technology in Secondary Substation Training



資料來源:綜研所資通室

2. 電力領域光纖感測技術應用
Application of Fiber Optic Sensing Technology in the Power Industry

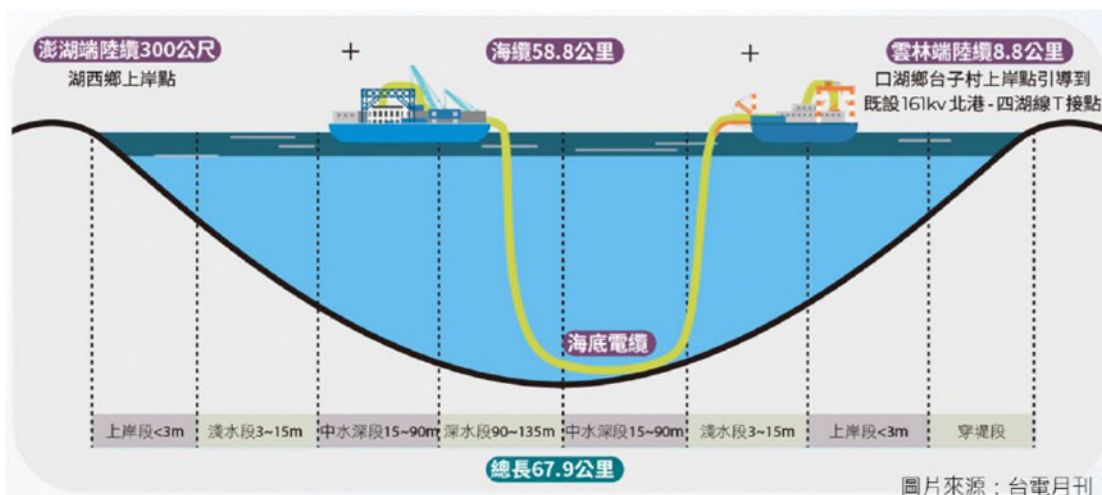

資料來源:台電工程月刊

3. 洞道專網物聯暨智慧巡檢應用導入研究
Research on the Application of IoT and Smart Inspection in Tunnel Using Private Networks

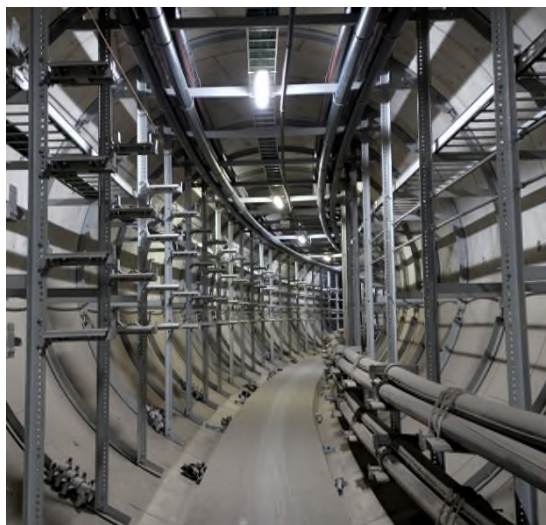

資料來源:綜研所資通室

4. 超高壓電纜洞道智慧結構監測研析
Analysis of Smart Structure Monitoring in Ultra-High Voltage Cable Tunnels

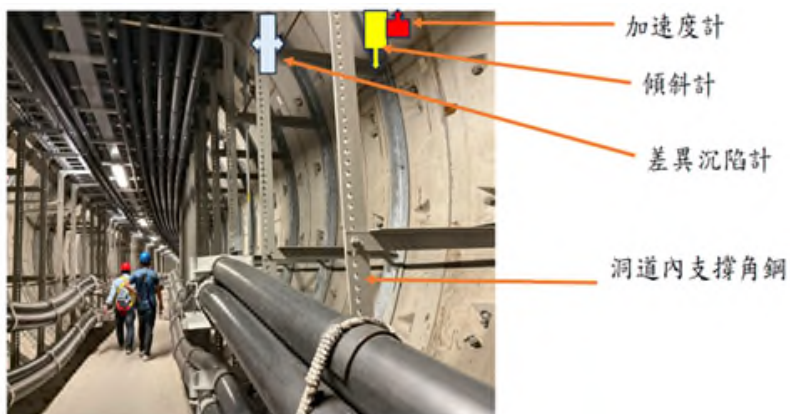

資料來源:綜研所資通室

5. 發電廠時間同步系統架構優化研究
Research on the Optimization of Time Synchronization System Architecture in Power Plants.



資料來源:綜研所資通室

- 資安與人工智慧研究組
Cybersecurity and AI Research Group

- IEC 62351 智慧電網資通訊安全標準及相關法規研究與導入
Research and import the IEC 62351 power system security standards and related regulations.

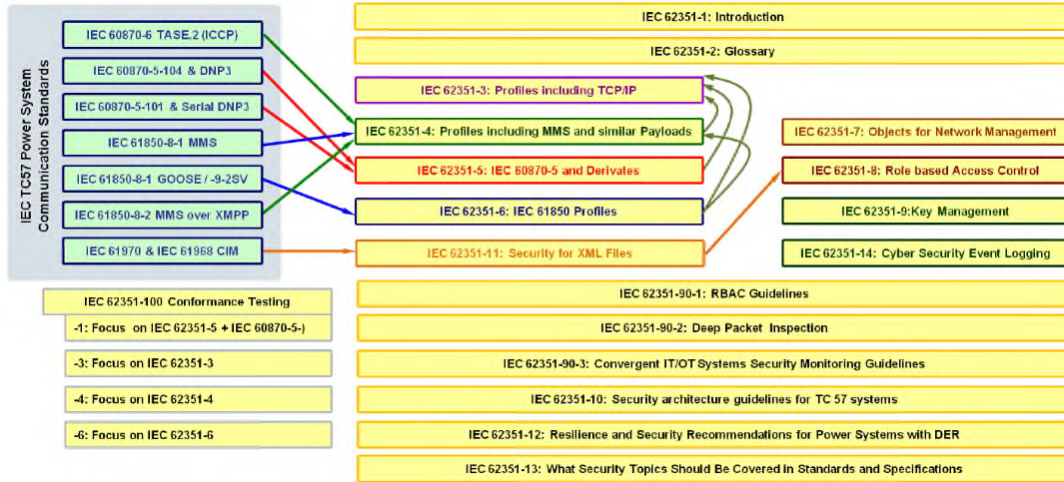

IEC 62351 電力系統安全標準
IEC 62351 power system security standards

- IEC 62443 工控系統資安標準研究與導入
Research and import the IEC 62443 industrial control system security standards.

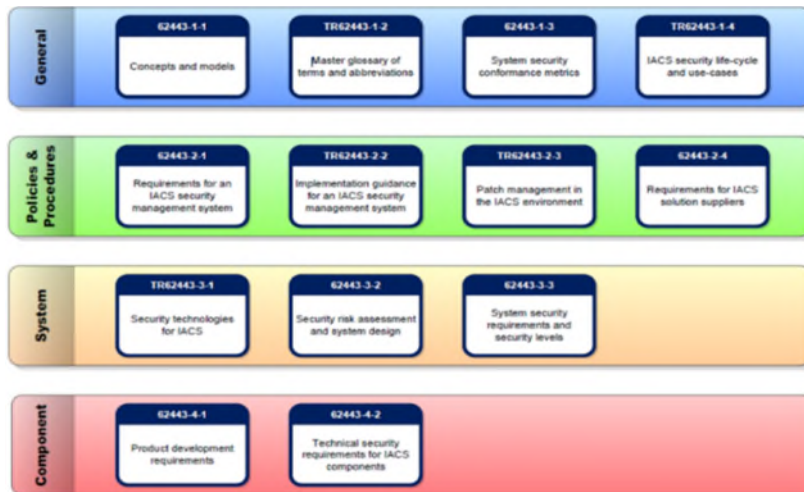

IEC 62443 工控系統安全標準
IEC 62443 industrial control system security standards

- 分散式能源相關資安標準應用研析
Research on the Application of Cybersecurity Standards for Distributed Energy Resources.

4. 電力物聯網資安檢測技術導入與建置
Introduction and Establishment of Cybersecurity Detection Technologies for EIoT.

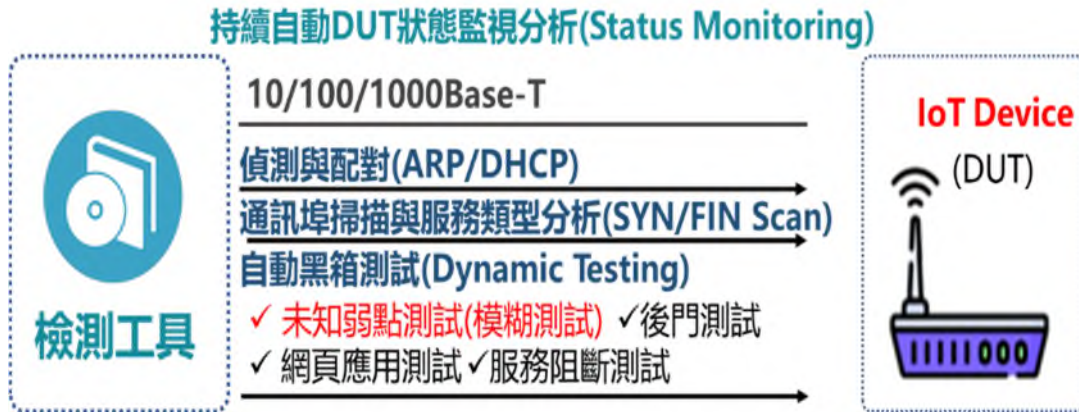

EIoT 資安檢測平台
EIoT Cybersecurity Detection Platform

5. 大語言模型 LLM 於電業領域之應用
Applications of Large Language Models (LLMs) in the electric power industry.

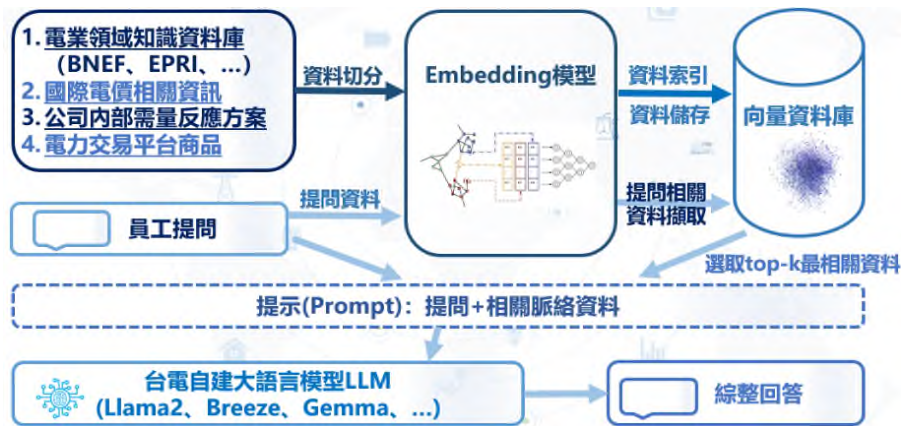

6. 建置台電地理圖資應用雲平台
Establishing a geographical information application cloud platform for TPC.



- 資通訊分析與應用研究組
ICT Analysis and Application Research Division

1. DER 國際資通訊標準研析與導入
Analysis and Implementation of International DER ICT Standards
2. DER 資通訊檢測、分析與應用
DER ICT Testing, Analysis, and Applications
3. XMPP 資通訊檢測與應用
XMPP ICT Testing and Applications
4. DER 虛實整合技術研究與應用
Research and Applications of DER Cyber-Physical Integration Technologies

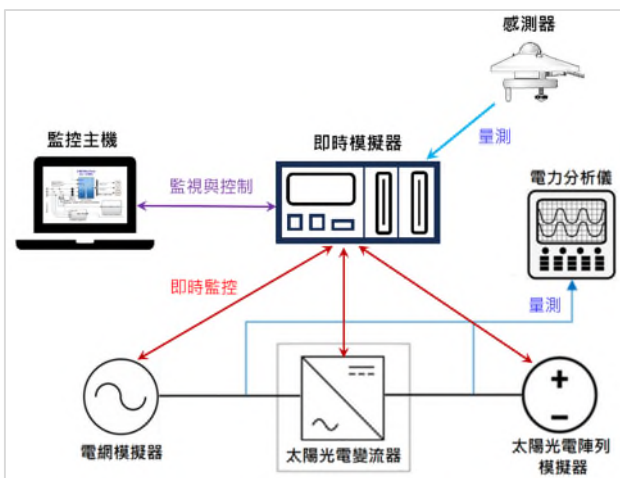

PV 虛實整合驗證平台

PV Cyber-Physical Integration Verification Platform

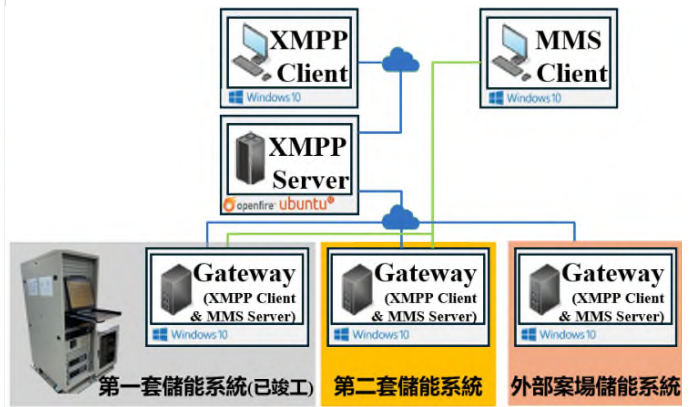

多儲能系統資通訊檢測平台

Multi-Energy Storage System ICT Testing Platform

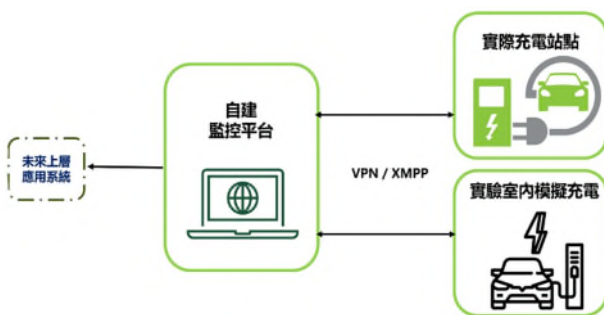

EV 充電資訊蒐集平台示意圖

Schematic Diagram of an EV Charging Information Collection Platform

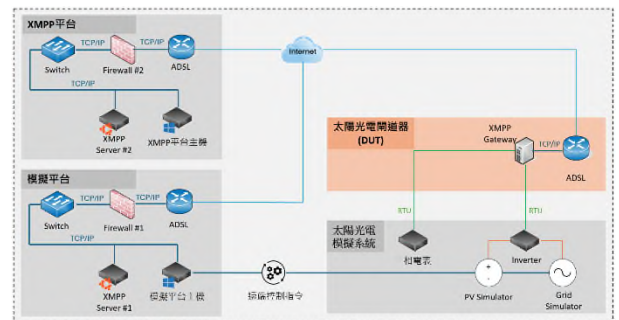

XMPP 閘道器檢測平台

XMPP Gateway Testing Platform

能源研究室 Energy Research Lab

- 發電渦輪機材料工程與壽命管理技術

Material Engineering and Life Management Technologies for Power Turbine

1. 渦輪機材料壽命評估技術(Technologies in Evaluating the Remaining Life for the Critical Turbine Components)
2. 氣渦輪機熱段組件再生處理及新製技術(Technologies in Refurbishment and Renew Manufacture Process for The Hot-section Components of Gas Turbine)
3. 渦輪機組件之破損肇因評估技術(Technology in Evaluating the Root Cause for The Fracture of Turbine Components)
4. 渦輪機組件之雷射鐳修技術(Technologies in Laser Welding Repairs of the Turbine Components)

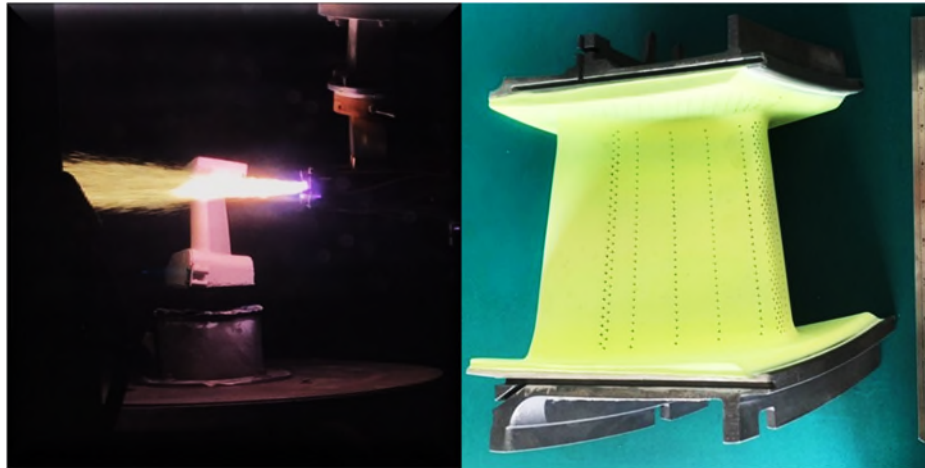

Si3D/501G 葉片絕熱塗層高能量及高效率噴塗製程

High-energy and efficiency spraying process for Si3D/501G blade insulation coatings

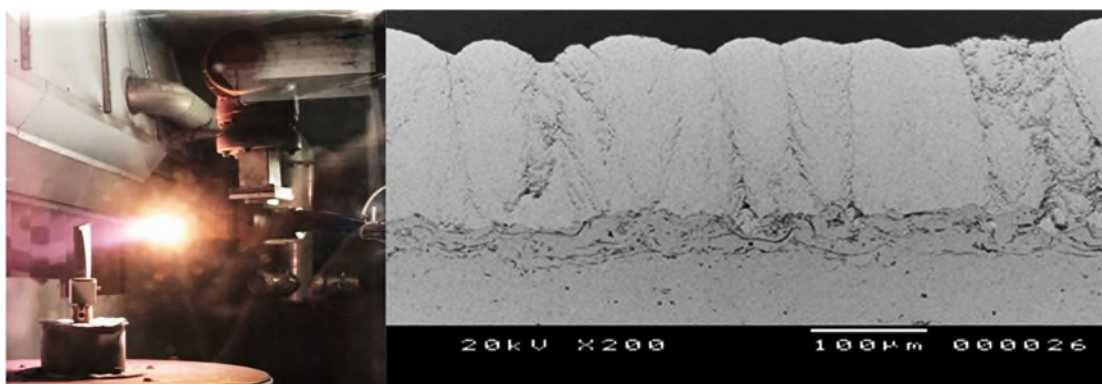

奈米結構絕熱塗層開發

Nanostructured Insulation Coating Development

- **發電鍋爐材料壽命評估技術**

Life Management Technologies for Utilities Boiler

1. 鍋爐組件材料壽命評估技術(Technologies in Evaluating Remaining Life for the Major Components of Utility Boilers)
2. 鍋爐爐管破損肇因分析與改善對策(The Root Cause Analysis of the Failure Parts and Countermeasures for Improvement of Boiler Components)
3. 超超臨界鍋爐材料高溫性質研究與老化評估技術 (Study of High Temperature Properties and Degradation Evaluation of Ultra-supercritical Materials)
4. 鍋爐監診系統開發與應用(Development and Application of Boiler Diagnosis System)
5. 室內無人機進行鍋爐內部巡檢，開發瑕疵爐管影像辨識技術(Using Indoor Drones for Internal Boiler Inspection and Developing Image Recognition Technology for Detecting Surface Defects in Boiler Tubes)



鍋爐無人機巡檢、影像辨識與破損分析
Drone inspection, image recognition and failure analysis

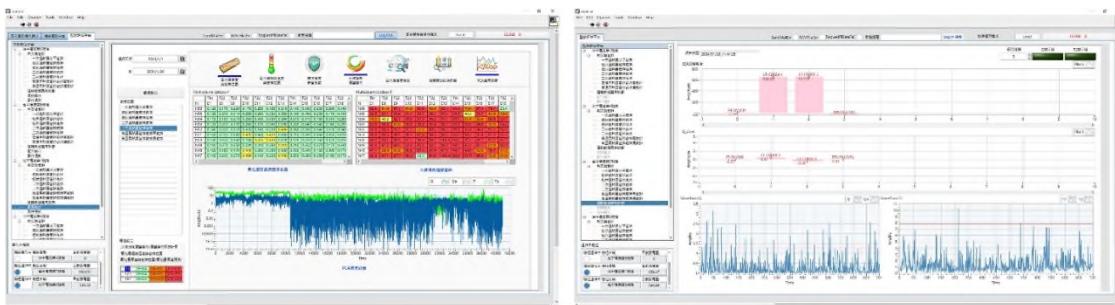

鍋爐監診系統
Boiler Diagnosis System

- 分散式發電系統應用技術

Technologies for the application of distributed generation system

1. 再生能源發電預測技術(Renewable Energy Forecasting Technology)
2. 再生能源機組運維監控及診斷技術(Renewable Energy Units Intelligent Maintenance Technology)
3. 氣象觀測及預報資料整合應用(Integrated Application of Meteorological Observation and Forecast data)
4. 水電解產氫技術(Water Electrolysis Hydrogen Production Technologies)
5. 燃料電池及氫能發電相關技術 (Fuel Cell and Hydrogen Power Generation Technologies)
6. 分散式電源管理技術(Integration Research of Distributed Power System)



綠能氣象預測平台
Green Energy Power Forecasting Platform



併網型固態氧化物燃料電池發電系統(SOFC)
Grid-connected Solid Oxide Fuel Cell (SOFC) Power Generation System

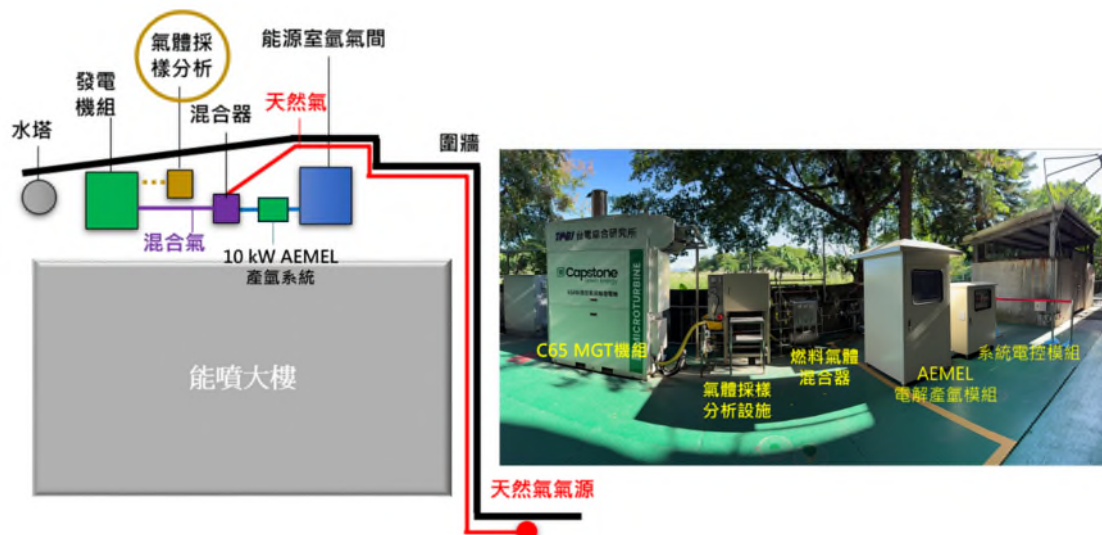

鹼性膜電解產氫系統(AEMEL)整合混氫微型渦輪發電機(MGT)性能試驗場域

AEM Electrolyzer(AEMEL)–Hydrogen Blended MGT Integrated Performance Test Site

- 火力機組效能評估與氫能混燒發電應用研究

Research on Thermal Power Unit Performance Evaluation and Hydrogen Co-firing Power Generation Applications

1. 火力機組運轉性能即時監測系統技術(Technologies for Real-time Performance Monitoring and Evaluation of Thermal Power Units)
2. 火力機組燃燒熱流場模擬技術(Combustion and Heat Flow Field Simulation Technologies for Thermal Power Units)
3. 火力機組低碳燃料混燒技術(Technologies for Low-Carbon Fuels Co-firing in Thermal Power Units)
4. 電廠輔機設備流況模擬分析技術(Flow Simulation Analysis Technologies for Power Plant Auxiliary Systems)
5. 發電設備廢熱回收技術(Technologies in Recovering Waste Heat of Power Generation Facilities)
6. 產氫系統與混氫發電機組之整合評估技術(Integrated Assessment Technologies for Hydrogen Production Systems and Hydrogen-blended Power Generation Units)



燃煤鍋爐過熱器線上結渣檢測
Online Slagging Monitoring of Superheaters in Coal-Fired Boilers

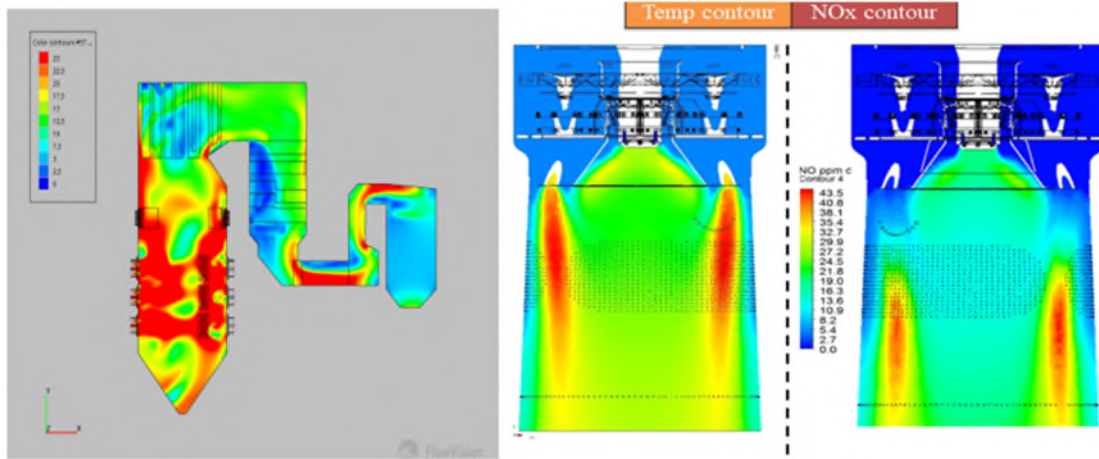

火力機組燃燒熱流場模擬分析技術
Combustion and Heat Flow Field Simulation Technologies for Thermal Power Units

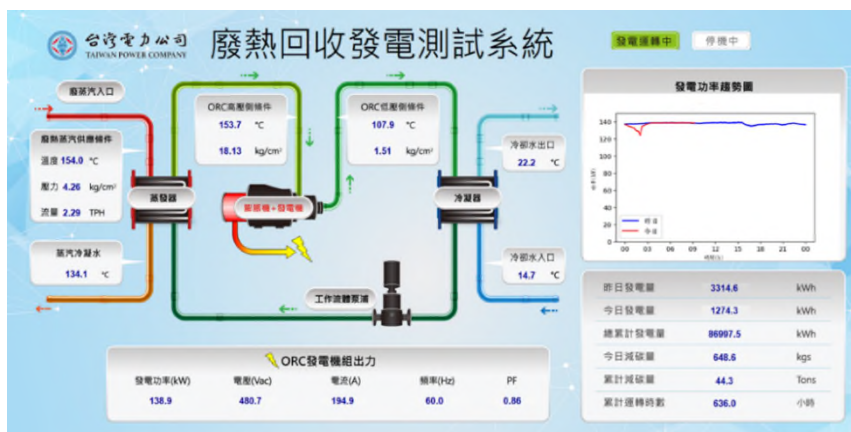

廢熱回收發電測試系統
Waste Heat Recovery Power Generation Test System

- 發電設備結構力學之評估、模擬與監測技術
Structural Mechanics Analysis & Monitoring of Power Generation Equipment

1. 發電設備振動分析與應力評估技術(Technologies in Vibration Diagnosis and Stress Evaluation for Power Generation Equipment)
2. 電廠迴轉機振動肇因與改善對策分析技術(Technologies in Evaluating the Root Cause for Rotary Machines Vibration and the Countermeasures for Improvement)
3. 發電設備運轉狀態監測與健康診斷技術(Technologies in Condition Monitoring System and Structural Health Monitoring of Power Generation Equipment)
4. 設備組件破損肇因與改善對策分析技術(Technologies in Evaluating the Root Cause for the Fracture of Facility Component and the Countermeasures for Improvement)
5. 設備組件有限元素分析及模態試驗(Finite Element Analysis and Modal Testing of Facility Component)

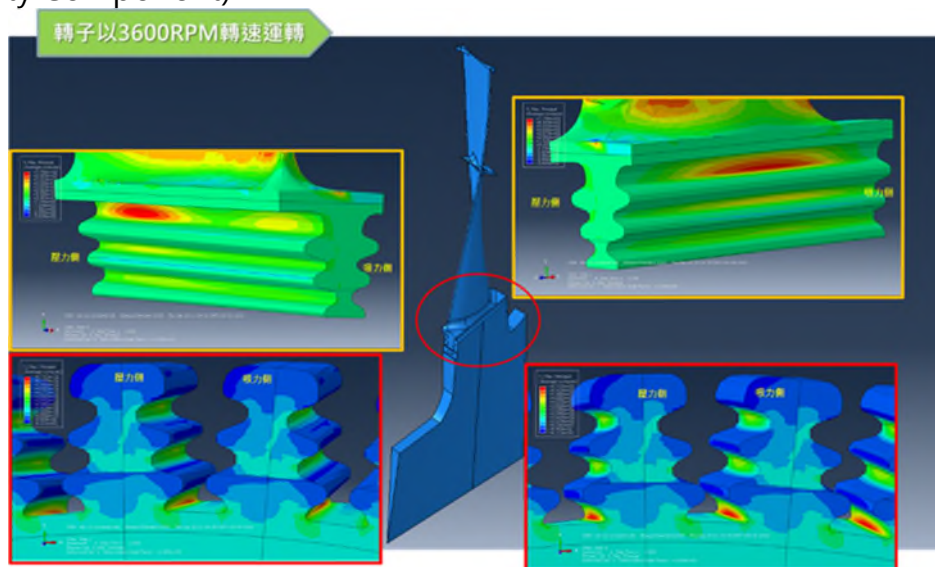

汽機葉片及轉子鳩尾槽應力分析

Stress Analysis of the Turbine Blade and Disk dovetail groove

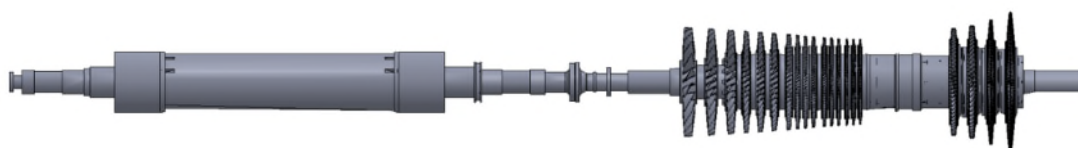

氣渦輪機及發電機轉子動力分析

Dynamics Analysis of the Gas Turbine and Generator Rotor

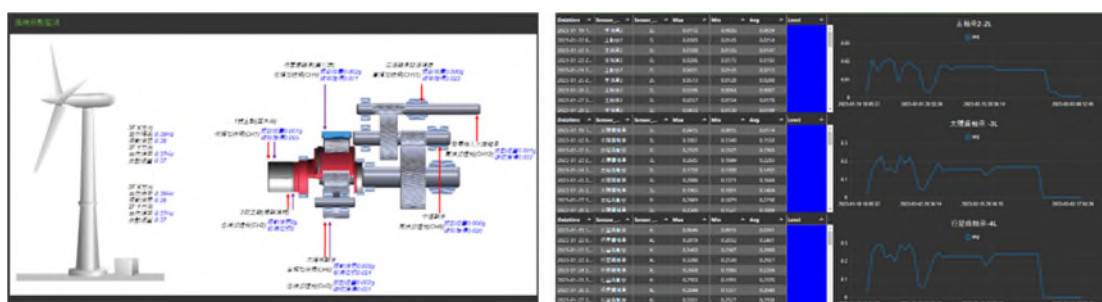

風機運轉狀態監測與健康診斷技術

Technologies in Condition Monitoring System and Structural Health Monitoring of Wind-turbines



負載管理研究室 Load Management Research Lab

需求面電能分析與運用技術

Demand Side Electric Energy Analysis and Application Technology

1. 智慧電網結合AMI數據分析違規用電行為可行性研究(Feasibility study in Illegal Electronic Activity with AMI Data Analysis and Smart Grid)
2. 整合新興分散式資源應用於電力調度之技術規範研析(Research and Analysis on Technical Specifications of Integrating Emerging Distributed Resources for Power Dispatching)
3. 再生能源電源高占比時段之負載提升需量反應機制研究(Research on demand response of load increase during periods of high proportion renewable energy)
4. 需求面管理措施精進策略及關鍵要素設計研析(Research and analysis on the improvement strategy and key element design of demand side management measures)
5. 太陽光電結合儲能計量及再生能源數據應用精進之研究(Research on enhance study of solar power combined with PV energy storage and application regrading renewable energy meter data)
6. 用戶側可控資源之雙向需量反應機制研究(Research on Bidirectional Demand Response Mechanisms for Demand Side Controllable Resources)
7. 運用高低壓AMI資訊及人工智慧判斷違規用電研究(Study on Detecting Illegal Electricity Usage by Applying High/Low Voltage AMI Data and AI)
8. 運用AI知識庫之高壓用戶需量反應特性查詢系統精進研究(Improved research on high-voltage user demand response characteristics query system using AI knowledge base)

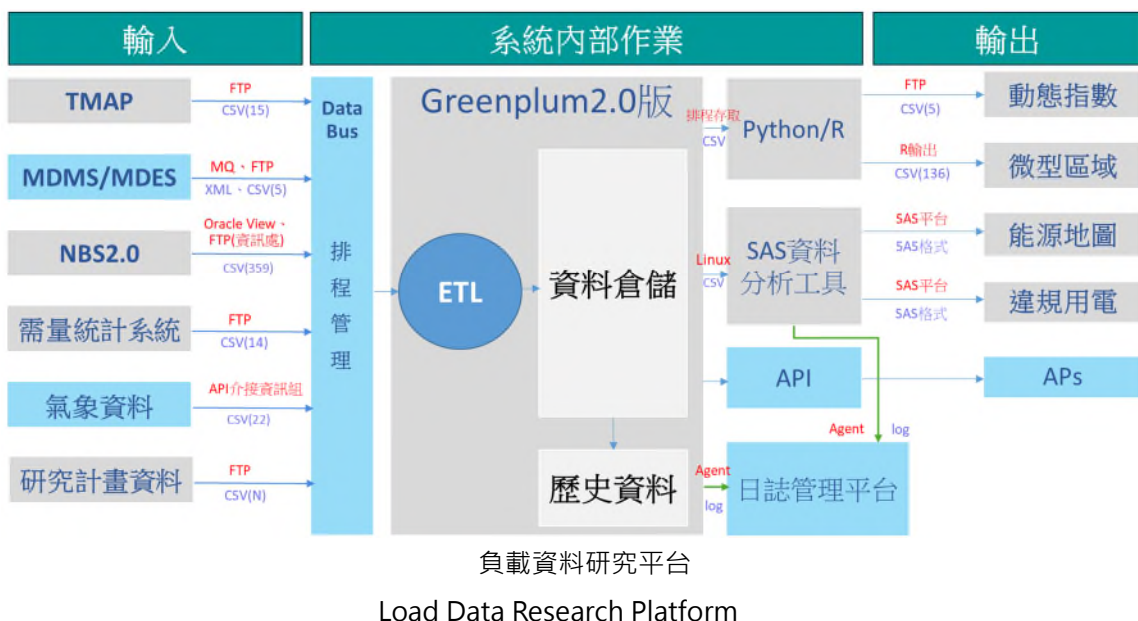

- **Esgator 技術與研發應用**
Esgator Technology and Applications

1. 能源技術與聚合服務(Esco and Aggregator Service)
2. 分散式能源整合技術(Distributed Energy Resources Integration Technology)
3. 微電網技術與應用(Microgrid Technology and Applications)

Esgator服務平台
系統架構



Esgator 平台架構

Integrated Development Mapping Platform Structure of Esgator

- **智慧配電維護技術研究**

A Study on Maintenance Techniques of Smart Distribution System

1. 用戶用電設備設計資料審查及審驗圖文管理系統開發(To Develop the Management System for the Customer Equipment's Design Review and Map Information Verification)
2. 配電工程設計輔助圖面電腦化研究(Computerized Research on Auxiliary Design of Power Distribution Engineering Design)
3. 封印鎖管理機制探討與管理系統建置之研究(Study of Discussing Seal Management Policy and Disposing Management System)
4. 結合用戶群代表服務提升需求反應執行成效之可行性研究(Feasibility Study on Improving the Effectiveness of Demand Response Execution in Combination with Aggregator Services)

5. 再生能源管理資訊系統精進研究(A Integration Research of Renewable Energy Management System and Feeder Hosting Capacity Visualization System)
6. 饋線可併網容量視覺化系統精進研究(A Study of Improving Feeder Hosting Capacity Visualization System)
7. 配電規劃資訊系統結合配電級再生能源可併容量查詢系統暨網頁化(To make the web page of Distribution planning information system combined with Feeder GIS)
8. 電度表、變比器資訊數位化管理之研究
A Study on Digital Information Management of Power Meter and Transducer
9. 用戶用電設備設計資料應用 BIM 技術增進圖資交付與電腦輔助法規檢核之研究
Research on the application of BIM technology to the design data of consumer electrical equipment to enhance the delivery of graphics and data and computer-aided regulatory review

再生能源圖資管理研究發展平台 系統架構

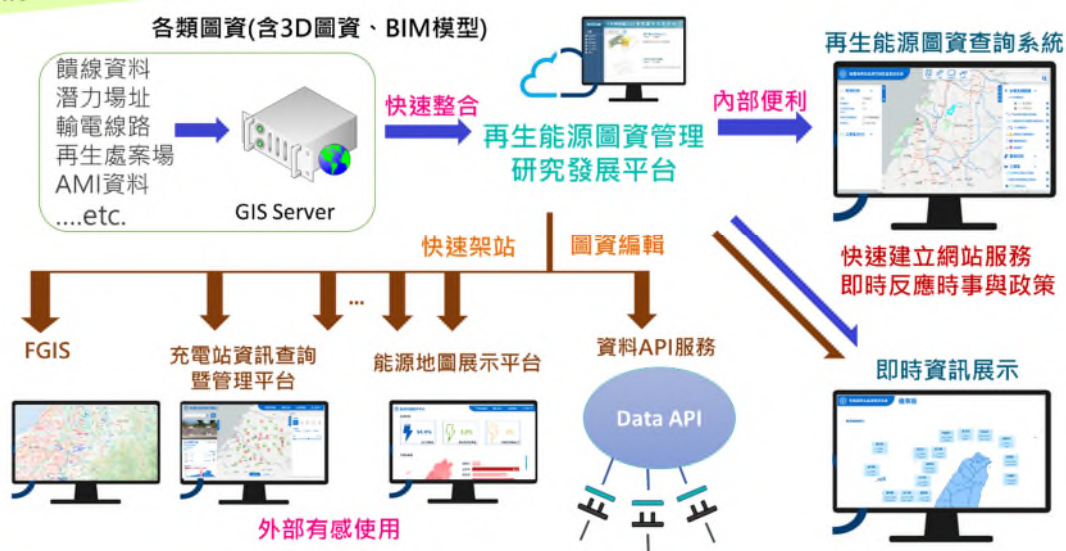

再生能源與配電設備圖資整合發展平台架構
Integrated Development Mapping Platform Structure of Renewable Energy
and Power Distribution Equipment

- **用戶智慧用電體驗與節能應用技術**
User Smart Electricity Experience and Energy-saving Application Technology

1. 家庭、建置與社區型微電網與能源管理系統資通訊標準研究 (Research on information and communication standards for household, residential and community microgrids and energy management systems)
2. 家庭、建置與社區型微電網與能源管理系統節能技術研究 (Research on energy-saving technologies for household, residential and community microgrids and energy management systems)



3. 用戶端能源管理應用與推動策略研究 (The study on the application and roadmap of customer-side energy management system)
4. 自動需量反應通訊協定技術開發研究 (Research and development of automatic demand response communication protocol technology)
5. 自動需量反應與能源管系統整合應用研究 (Research on the integration and application of automatic demand response and energy management system)



家庭能源管理系統架構

home energy management system architecture

⚡ 化學與環境研究室

Chemistry and Environmental Research Lab

- **環境與水資源管理技術**

Environment and Water Resource Management

1. 超臨界機組水處理技術(Water Treatment for Supercritical Power Plant)
2. 超臨界機組線上水質分析技術(On-line Water Analysis For Supercritical Power Plant)
3. 電廠廢水處理回收減量(Waste Water Recovery and Reduction)
4. 廢水零排放規劃評估(Evaluation of Zero Wastewater Discharge Planning)
5. 微藻固碳與廢水回收整合技術(Integration of Microalgae-based Carbon Fixation and Waste Water Recycling)



薄膜試驗設備

Membrane Treatment Equipment



微藻固碳養殖

Microalgae Carbon Fixation Facility



蒸發試驗設備

Evaporation Treatment Equipment



氨氮廢水試驗設備

Ammonia Nitrogen Test Equipment

• 二氧化碳減量及再利用技術

Carbon Dioxide Reduction and Utilization for Fossil Fuel Power Plants

1. 化學吸收法於二氧化碳吸脫附技術開發與效益評估(Development and Evaluation of Chemical Absorption Method in CO₂ Absorption and Desorption Process.)
2. 先導物理固態吸附二氧化碳捕捉程序研究(Research on Performance of CO₂ Capture Process by Solid Adsorbent.)
3. 碳捕捉前處理技術開發(Development of Pretreatment Process before Main Carbon Capture Process.)
4. 碳捕捉、封存與運輸技術經濟分析研究(Research of technical economic analysis on Carbon Capture, Storage and Transportation)
5. 二氧化碳地質封存之地質安全與風險評估(Geological Safety and Risk Assessment of CO₂ Geological Storage)
6. 二氧化碳再利用技術評估與開發(Development and Evaluation of CO₂ Utilization Technology.)
7. 二氧化碳於農業生產之應用—植物工廠技術(Application of Carbon Dioxide for Agricultural Production: Plant Factory Technology)

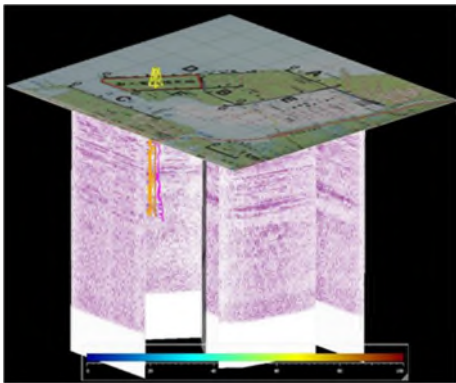

彰濱場址三維地球物理資料展示

3D Geophysical Model of ChangBin Site



液態吸收程序整合熱管理技術

Chemistry absorption process by heat integration



固態吸附法二氧化碳捕捉技術

Solid adsorption technology for capture CO₂



減碳技術園區-微型測試區

Carbon Reduction Technology Campus - Mini-Testers Region

- 電廠煙氣淨化與固體副產物處理技術研究

Study on Flue Gas Cleaning and Solid Biproduct Utilization Techniques of Coal-Fired Power Plant

1. SCR 觸媒性能分析及活性管理 (SCR de-NOx Catalyst Quality Performance Analysis and Activity Management)
2. 低溫 SCR 脫硝觸媒技術開發 (Low Temperature SCR de-NOx Catalyst Technology)
3. 煤灰資源化利用技術(Coal Ash Resource Utilization Technology)
4. 巨積混凝土溫控技術發展 (Development of Temperature Control Technology for Massive Concrete)
5. 低碳循環營建技術發展 (Development of Low Carbon Circular Construction Technology)
6. 工程減碳技術與策略規劃(Engineering Carbon Reduction Technology and Strategic Planning)

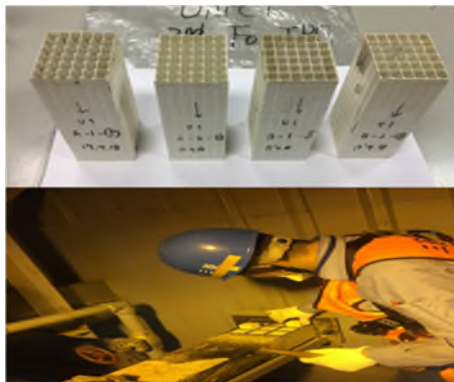

觸媒取樣及分析

Catalyst Sampling and Analysis

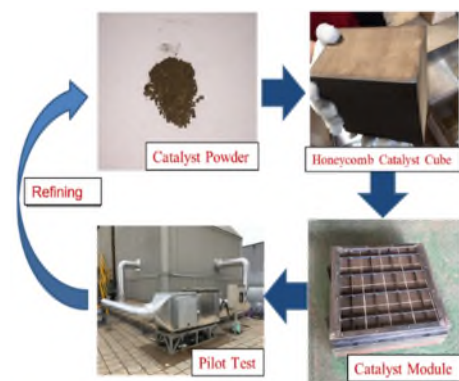

觸媒開發及模廠測試

Catalyst Development and Pilot Test

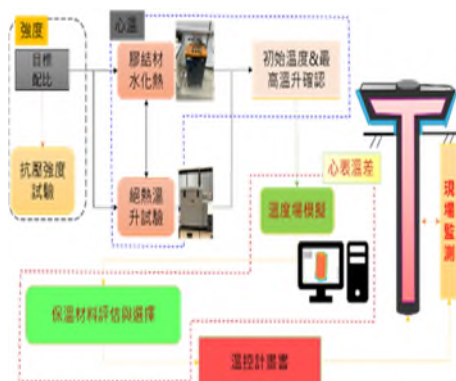

巨積混凝土溫控技術發展流程

Development Process of Temperature Control Technology for Mass Concrete



低碳建築技術發展

Development of Low Carbon Circular Construction Technology

• 電化學與儲能關鍵材料技術

Key Technology for Electrochemistry and Energy Storage Materials

1. 二次電池在再生能源電力儲存之評估研究(Evaluation of Secondary Battery For Renewable Energy Storage Application)
2. 固態氧化物燃料電池關鍵技術(Key Technology On Solid Oxide Fuel Cell(SOFC))
3. 電廠腐蝕監測與陰極防護(Technologies on Corrosion Monitoring And Cathodic Protection For Power Plant)
4. 電池線上監測、容量測試及壽命評估(On-line Monitoring, Capacity Measurement and Life Assessment on Battery used in Power Plant)
5. 陸上及海上風塔與基樁腐蝕防治系統設計與劣化評估(Design and Deterioration Assessment of Onshore and Offshore Wind Tower, and Foundation Corrosion Prevention System)
6. 電化學水處理技術研究 (Research on Electrochemical Water Treatment Technology)



鈦液流電池儲能系統

Vanadium Redox Flow Battery Energy Storage System (125kW-750 kWh)

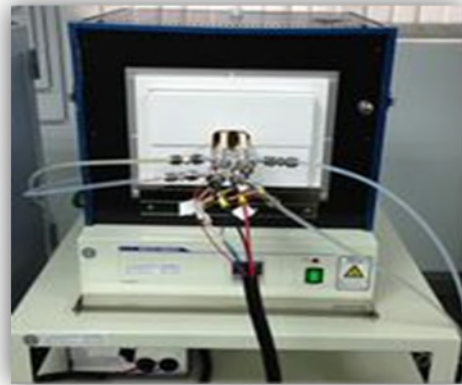

SOFC 單電池測試平台

SOFC Single Cell Test System



電化學水處理模廠試驗設備

Electrochemical water treatment pilot test equipment

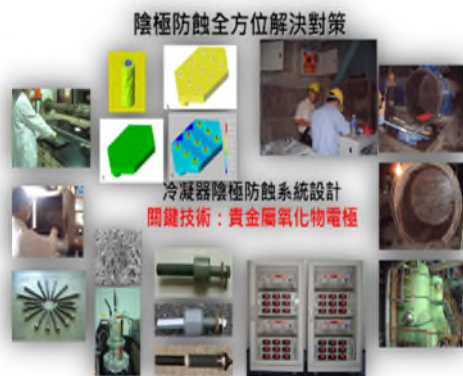

陰極防蝕全方位解決對策

冷凝器陰極防蝕系統設計
關鍵技術：貴金屬氧化物電極

電廠陰極防蝕系統設計

Cathodic Protection System Design for Power Plan

- 電力設施周邊生態保育與海洋牧場技術研究

Studies on the Ecological Conservation and Marine Ranch Around Power Facilities

1. 電業生態保育研究(Ecological Conservation Around Power Facilities)
2. 海洋牧場技術研發(Research and Development of Marine Ranch Technology)
3. 能源轉型之生態議題研究(Studies on Ecological Issues of Energy Transition)
4. 生態檢核專業服務及保育研究(Ecological Check Professional Services and Conservation Research)
5. 棲地經營管理專業服務及保育研究(Habitat Management Professional Services and Conservation Research)
6. 水產養殖、海洋生態專業服務及研究(Aquaculture, Marine Ecology Professional Services and Research)

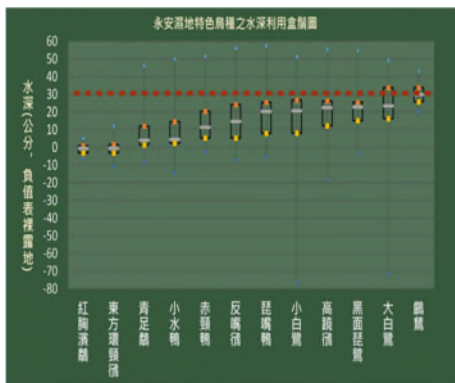

永安濕地棲地保育及水位調控技術
Yongan wetland habitat conservation and water level regulation technology

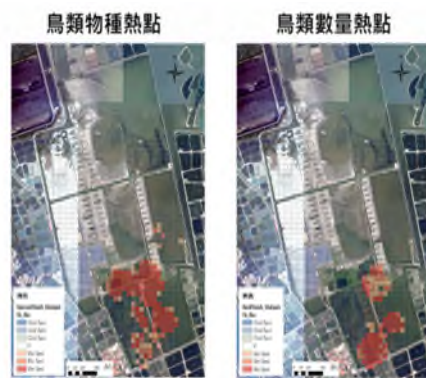

生態調查及生物資源空間分析·環境衝擊決策依據
Ecological investigation and spatial analysis of biological resources, providing the basis for environmental impact decision-making



海洋牧場箱網養殖設備
Marine Farm Facility

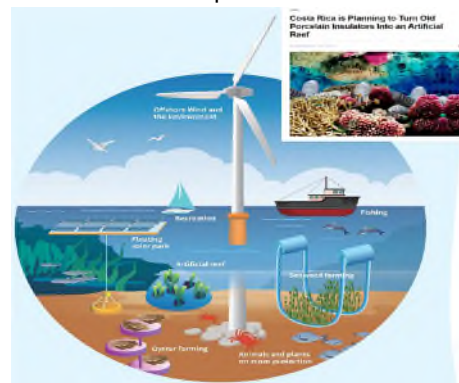

電業生態保育研究
Ecological Conservation Around Power Facilities

⚡ 高壓研究室 High Voltage Research Lab

- 電力設備智慧診斷與災害防制技術平台
Power Equipment Intelligent Diagnosis and Disaster Prevention Technology
 - 電力設備狀態監測與診斷
Power Equipment Condition Monitoring and Diagnostics
 1. 變壓器狀態監測與 AI 智慧診斷技術 (Transformer Condition Monitoring and Artificial Intelligent Diagnosis Technology)
 2. 四足型機器人應用於超高壓變電所與水力發電廠之自動巡檢 (Utilizing Quadrupedal Robots for Autonomous Inspection of EHV Substations and Hydropower Facilities)

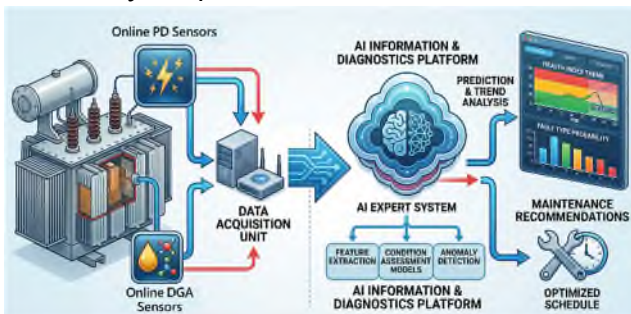

變壓器線上 PD 與 DGA 監測系統加值應用

[圖片來源：AI 生成]

Enhanced Applications for Online PD and DGA Monitoring Systems



機器人於變電所進行自動巡檢

Robot performing autonomous inspection at a substation

- 閃電偵測與雷害防制
Detection and Countermeasures for Lightning Hazard

1. 閃電偵測 (Lightning Detection)
 - (1) 閃電現象偵測與資料庫建立 (Lightning Detection and Updating the Lightning Database)
 - (2) 即時閃電資訊傳送服務 (Real Time Transmission Service of the Lightning Data)
 - (3) 提供歷史閃電資訊服務 (Historical Lightning Information Inquiring Service)

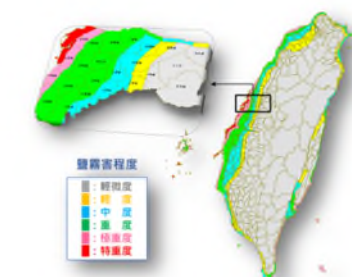

台灣地區鹽害程度分佈圖
Salt Contamination and Distribution Map of Taiwan



落雷追蹤預警軟體
Lightning Tracking and Alert System

2. 輸電線路之雷擊風險評估研究 (Lightning Strike Risk Assessment of Overhead Transmission Line)

- **輸電鐵塔塔基安全監測**

- Transmission Tower Foundation Safety Monitoring**

- 1. 塔基監測系統 (Tower Foundation Monitoring System)
 - 2. 邊坡穩定分析及人工監測 (Analysis and Manual Monitoring of Slope Stability)
 - 3. 塔基顏色維護模式精進 (Enhancement of Tower Foundation Color Maintenance Pattern)

- **鹽害防制與礙子特性**

- The Characteristics of Insulators and Countermeasures for Salt contamination**

- 1. 台灣地區鹽害程度調查 (Investigation of Salt Contamination in Taiwan)
 - 2. 評估礙子絕緣性能與特性試驗分析 (Evaluation of Insulator Insulation Performance and Characteristic Test)
 - 3. 深度學習應用於礙子洩漏電流推估之研究 (Research on Insulator Leakage Current Estimation Using Deep Learning)
 - 4. 大氣環境對鹽霧污染關聯性之研究 (Study on Correlation Between Atmospheric Environment and Salt-Contamination)

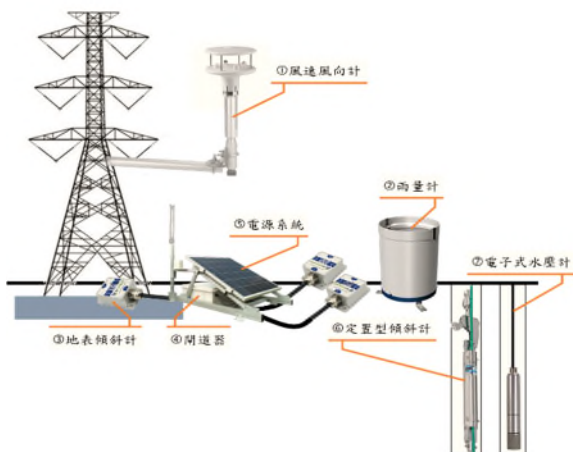

鐵塔安全監測系統

Tower Foundation Monitoring System

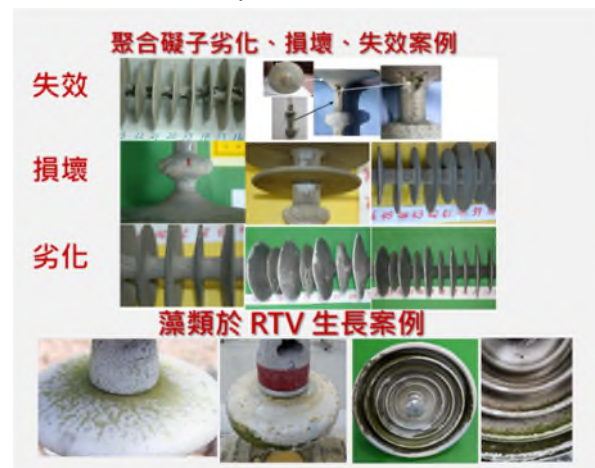

聚合礙子劣化、損壞、失效案例

Case Studies of Polymer Insulator Degradation, Damage, and Failure

- **電力設備即時動態模擬技術發展應用**

- Application of Real-Time Simulation for Power System Equipment**

- **電力系統即時電磁暫態模擬分析技術**

- Power System Real-Time Electromagnetic Transient (RT-EMT) Simulation and Analysis**

- 1. 即時電磁暫態模型建立 (RT-EMT Based Modeling)
 - (1) 大型電網電磁暫態模型(Large-scale Power System EMT Model)
 - (2) 變流器型資源電磁暫態模型(Inverter-based Resources EMT Model)

2. 即時電磁暫態模擬與分析(RT-EMT Simulation and Analysis)

(1) 系統保護與控制 (System Protection and Control)

(2) 停電事故肇因 (Root Cause of Outage)

(3) 操作程序驗證 (System Operating Procedure Verification)

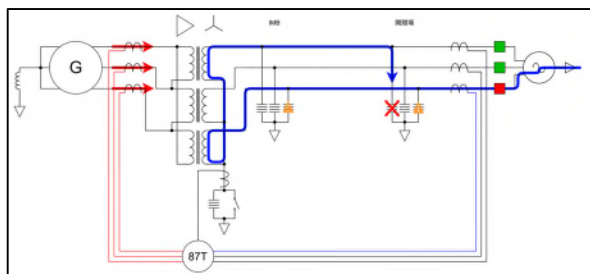

停電事故肇因分析
Analysis of Outage Root Cause

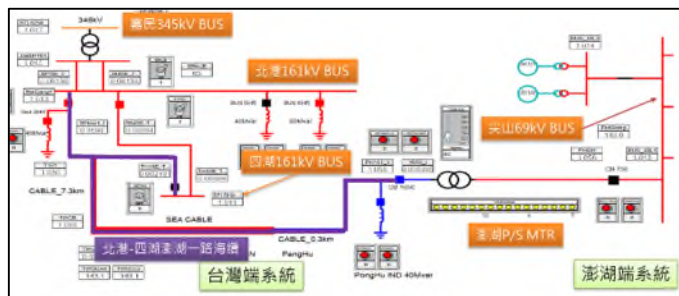

台澎系統 RT-EMT 模型
RT-EMT Model for Taiwan-Penghu System

◦ 電力設備硬體迴路測試技術

The Hardware-in-the-Loop Based Testing for Power System Equipment

1. 控制級硬體迴路測試(Control Hardware-in-the-Loop Testing)

(1) 保護電驛測試(Testing for Protection Relay)

(2) 饋線末端裝置測試(Testing for Feeder-Terminal- Unit)

(3) 微電網控制器測試(Testing for Microgrid Controller)

2. 功率級硬體迴路測試(Power Hardware-in-the-Loop Testing)

(1) 太陽光電變流器併網測試 (Testing for Interconnection of PV Inverter with Power Systems)

(2) 儲能系統 PCS 併網測試 (Testing for Interconnection of ESS PCS with Power Systems)

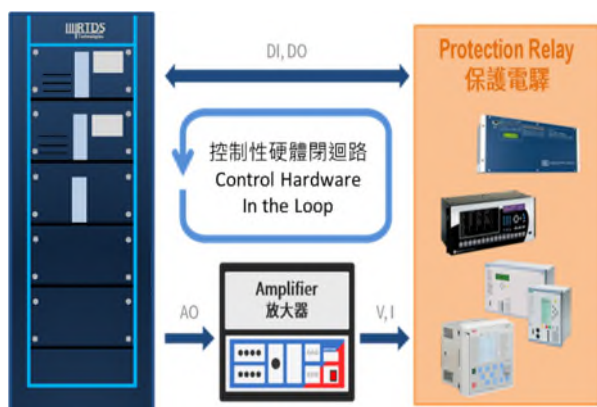

控制級硬體迴路測試架構圖
Control Hardware-in-Loop Testing

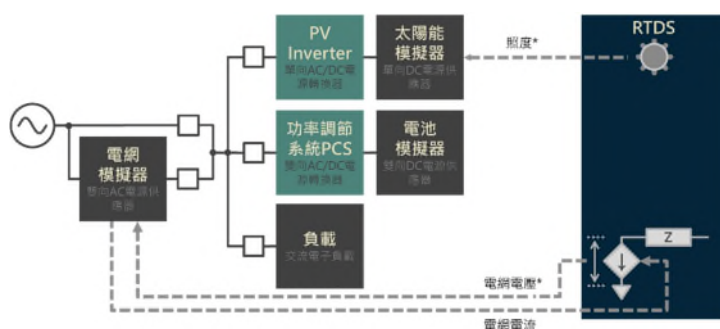

功率級硬體迴路測試架構圖
Power Hardware-in-Loop Testing Structure

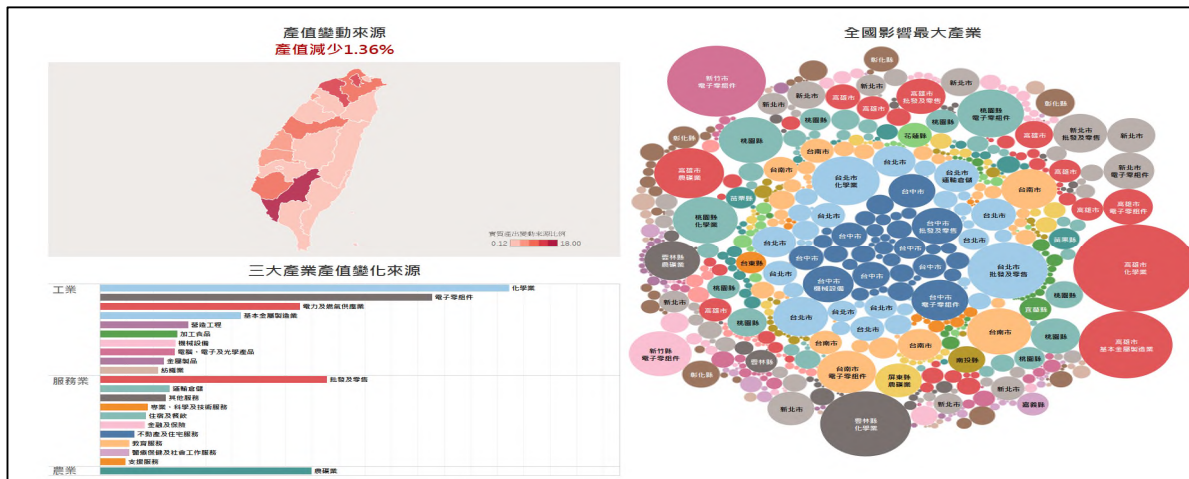

電價對縣市產值衝擊
The Impact of Electricity Cost on Inter-Counties Output

- 用戶經營與管理-用電行為分析與策略規劃
Customers Relationship Management Analysis on Electricity-Using Behavior and Strategic Planning

1. 用戶節電能力評估與特徵資料蒐集(Evaluation of Electricity-saving ability and feature collection)
2. 用戶用電行為分析 (Analysis on Electricity-Using Behavior of Users)
3. 用戶服務策略分析 (Analysis of Service Strategies for Users)

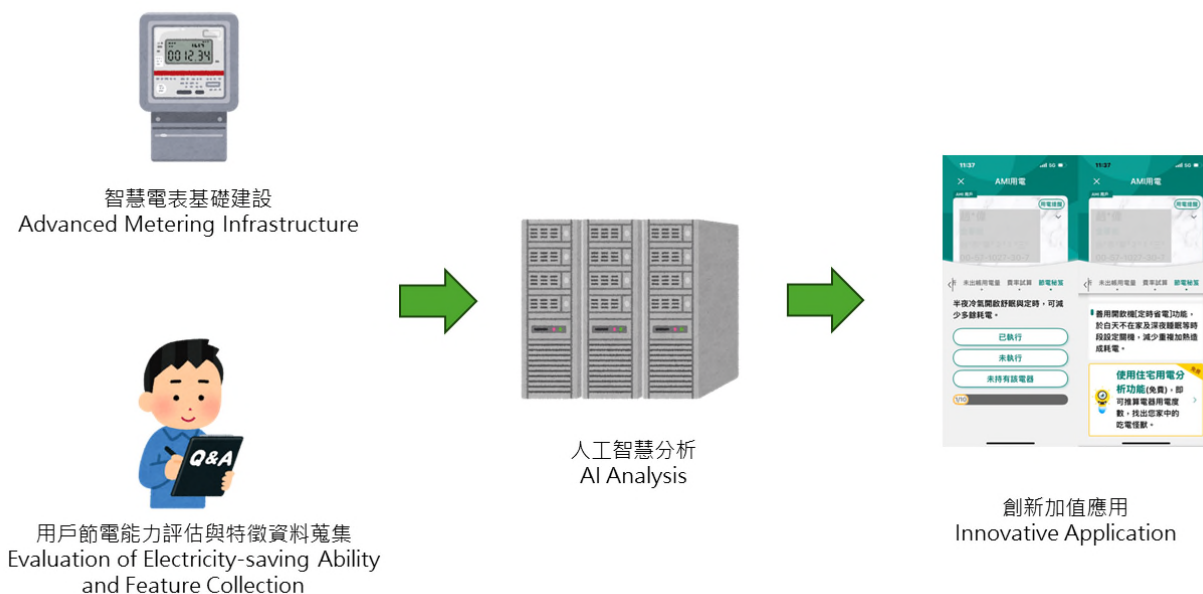

用電行為分析與策略規劃架構
Structure of the Analysis on Electricity-Using Behavior and Strategic Planning

- 技術經濟分析平台

Techno-Economic Analysis Platform

1. 需量反應措施成本效益評估模組(Cost and Benefit Assessment Module for Demand Response Measures)
2. 新興技術成本效益分析模組 (Cost and Benefit Analysis Module for Emerging Technology)
3. 碳風險評估與管理模組 (Carbon Risk Evaluation and Management Module)
4. 電價政策衝擊影響及風險管理模組(Electricity Pricing Policy Impact Assessment And Risk Management Module)

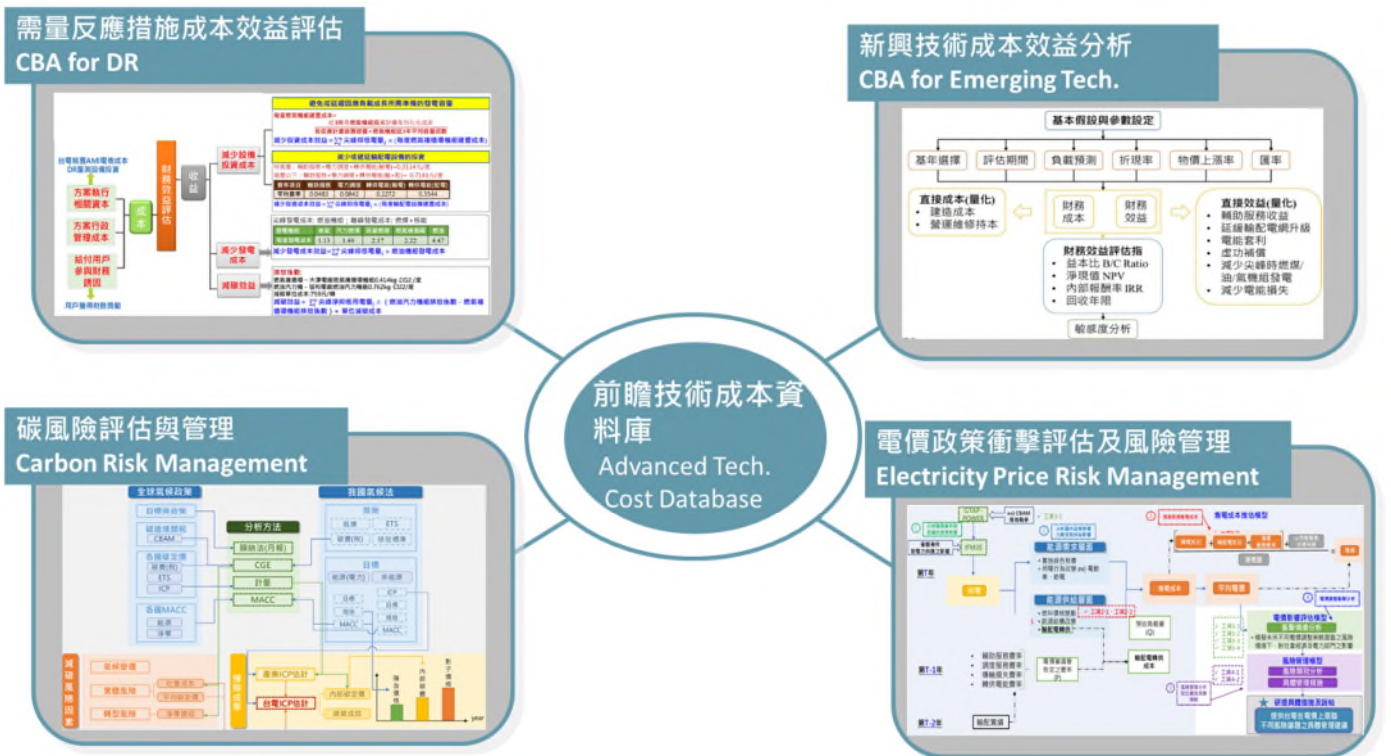

技術經濟分析平台核心資料庫與功能模組
Core database and functional modules of TAE platform

- 前瞻技術應用

New Technology Applications

1. 虛擬電廠(Virtual Power Plant, VPP)

- (1) 分散式能源應用 (Decentralized Energy's Applications)
- (2) 用戶智慧能源管理系統應用 (User Smart Energy Management System's Applications)
- (3) 電力交易應用 (Electricity Trading's Applications)
- (4) 虛擬電廠發展策略 (VPP's Development Strategy)

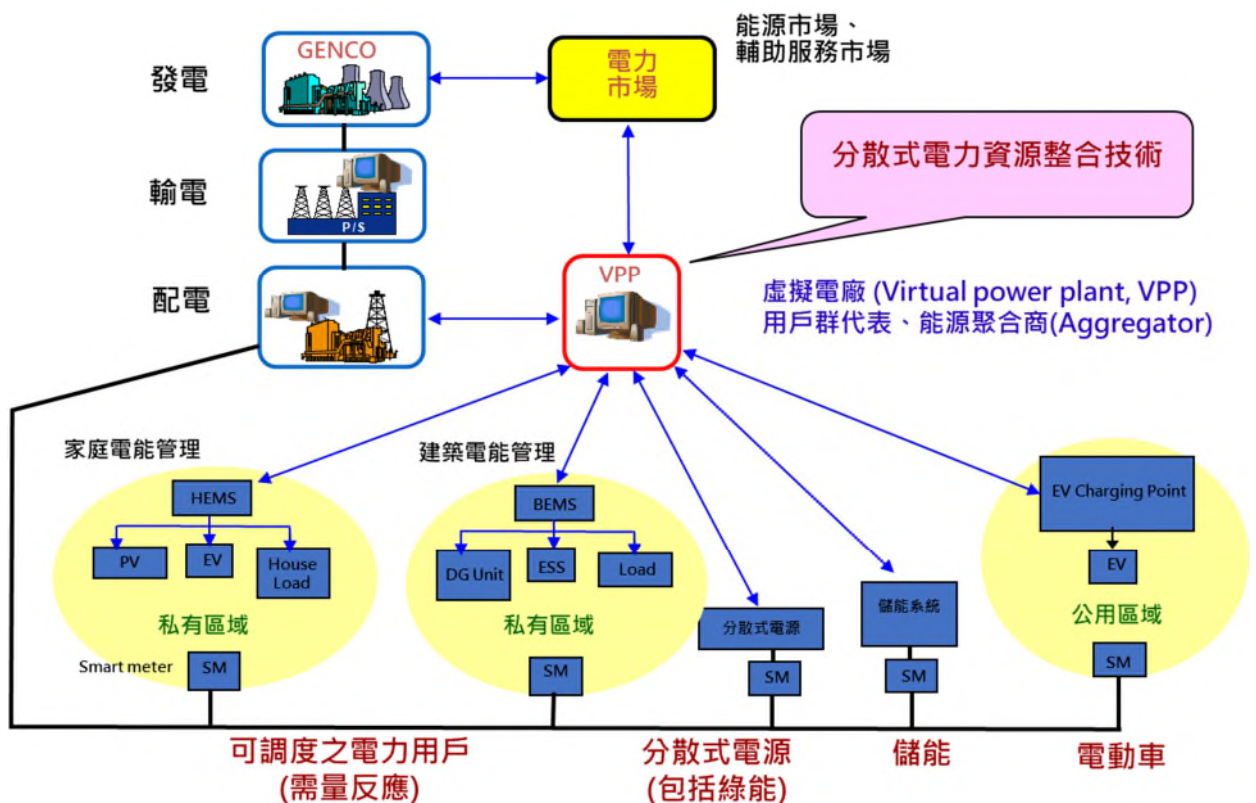

虛擬電廠之運作模式
VPP's Operation Mode

2. 分散式知識管理智能助理系統(Distributed KM Smart Work System)

- (1) 知識管理系統應用 (KM's Applications)
- (2) 知識管理行動化 (KM's Activation)
- (3) 知識管理整合人工智慧增值應用 (KM and AI's Value-Added Applications)



系統架構包含人工智慧Chatbot諮詢系統、專家即時回覆文字系統、分散式知識管理系統



知識管理智能助理系統
KM Smart Work System

試驗業務 Testing Services

⚡ 電力設備試驗組

Power Apparatus Testing Section

- 發、變電工程電力設備完工試驗
Power plant & Substation Apparatus Test
 - 變壓器、氣體斷路器等特性試驗
Transformer & Switchgear Characteristic Test
 - 接地電阻、線路常數等量測
Grounding Mesh Resistance & Transmission line Constant Test
 - 故障調查、分析、判斷
Fault Investigation & Diagnostics Test
 - 驗收試驗
Commissioning & Witness Test
- 交流遞升加壓、短路電流及加入系統對相試驗
Applied AC Voltage And Short Circuit Test On Power Transformers
 - 提供短路電流、電驛設定試驗
Applied AC current for Protective Relay Setting
 - 加入系統試驗
Synchronize & In-phase Test
- 發電機組效率、卸載及性能參數試驗
Generator Efficiency、Dumping、Governor Characteristic Test
 - 水力發電機組調速機性能參數
Hydro-generator Units Governor Test
 - 水輪機效率試驗
Hydro-power Station Turbine Efficiency Test
- 電力設備絕緣監測及維護試驗
Electrical equipment performance Insulation Test & Predictive maintenance On-Line Monitoring
 - 發電機及變壓器部份放電試驗
On line & off line partial discharge measurement on Large transformers and generators
 - 變壓器繞組變形試驗
Power transformers winding deformation diagnostics
 - 紅、紫外線熱影像檢測技術服務
Infrared & ultraviolet image inspection



變壓器絕緣試驗
Transformer Insulation Test



電廠變壓器遞升加壓試驗
Applied AC Voltage Test



水輪機組調速機性能試驗
Hydro-generator Units Governor Test



發電機部分放電試驗
Generator Partial Discharge Test

儀器組 Measuring Instrument Section

● 主要試驗內容 Major Test Items

- 電量標準之建立與維持
Establishment and Maintenance of Electricity Stand
- 新購儀器之特性試驗及品管用儀器之定期校驗
Characteristic Testing of Newly Purchased Instruments
Regular Calibration of Quality Control Instruments.
- 各發變電所配電盤儀表定期現場校驗
Regular On-Site Calibration of Switchboard Instruments
Various Power Substations.
- 儀控(IEC61850)及電力監控系統試驗
Instrument Control(IEC61850) and Power Monitoring System Test.
- 各種儀器及保護電驛之檢修
Overhaul of Various Instruments and Protective Relays
- 智慧型保護電驛及 GOOSE 邏輯策略系統 (IEC61850)試驗
Intelligent Electronic Device (IED) Relay and GOOSE Logical Strategy System Test.
- 保護電驛及儀控系統事故分析
Fault Analysis of Protection Relay and Instrument System.



智慧變電所 IED 電驛互操作性模擬測試系統
Smart Substation IED Station
Interoperability Simulation Test System



發電廠變電所 IED 功能特性驗
IED Functionality Verification in
Power Plants and Substations

● 電量校正實驗室校驗能量 Calibration Capability

- 直流電壓 DC VOLTAGE 1 mV ~ 1000 V ; $\pm 0.1\% \sim 6$ ppm
- 直流電流 DC CURRENT 0.5 pA ~ 1000 A ; $\pm 0.4\% \sim 130$ ppm
- 交流電流 AC CURRENT 0.1 A ~ 2000 A ; $\pm 0.5\% \sim 0.03\%$
- 交流電壓 AC VOLTAGE 2 mV ~ 1200 V ; 50 Hz ~ 30 kHz $\pm 0.1\% \sim 70$ ppm
- 電 功 率 ELECTRIC POWER 0 ~ 240 V · 0 ~ 5 A · 0 ~ 1 PF · $\pm 0.05\% \sim 100$ ppm
- 電 阻 RESISTANCE 10⁻⁴ ~ 10¹² Ω ; $\pm 0.1\% \sim 10$ ppm
- 電 容 CAPACITANCE 1 pF ~ 100 μF ; $\pm 0.1\% \sim 50$ ppm
- 電 感 INDUCTANCE 100 μH ~ 10 H ; $\pm 0.1 \sim 0.02\%$
- 相 位 PHASE 0 ~ $\pm 360,000^\circ$; $\pm 0.01\% \sim 0.005^\circ$
- 頻 率 / 時 間 FREQUENCY/TIME 0 ~ 100 MHz ; $\pm 10^{-9}$



精密儀器測試
Precision Instrument Testing

電表組 Electricity Metering Section

• 主要試驗內容 Major Test Items

- 電力用戶及發變電所電度表與變比器之校修
In-service Performance Tests of Electricity Meters and Instrument Transformers
- 新購電度表與變比器之驗收試驗、特性試驗及新型式之定型試驗
Acceptable Performance of New Type of Electricity Meters and Instrument Transformers
- 瓦時、交流高壓、交流大電流標準之建立與維持
To Maintain the Primary Standard and to Carry out the Entire Chain of Sequential Measurements between National Standard and Working Standards on Electricity Meter and Instrument Transformer Field
- 電力用戶事故鑑定與分析
Analysis and Inspection of Power Measurement Diagnostics on End Users
- 新測試設備研發
Development of New Testing Equipment
- 高低壓智慧型電表 AMI 性能測試平台之建立
To Establish The Platform on Performance Test of the Advance Metering Infrastructure
- 電表與通訊模組交互可用性測試
Operability Testing between Electric Meters and Communication Modules

• 主要試驗能力 The Major Facilities of Testing and Capability

- 單 / 三相電度表試驗設備
Test system for Electricity Metering
110 / 220 / 380V ; 0.25 ~ 200A ; $\pm 0.3\%$
- 標準瓦時計校正設備
Watt-hour Standard Calibration System
110 / $\sqrt{3}$ ~ 240V ; 0.25 ~ 20A ; $\pm 0.07\%$
- 精密比壓器試驗設備
Precision Potential Transformer Test System
110 / $\sqrt{3}$ ~ 12,000V ; $\pm 0.001\%$
- 精密比流器試驗設備
Precision Current Transformer Test System
5 ~ 5,000A ; $\pm 0.001\%$
- 感應耐電壓試驗設備
Induce Voltage Withstand Test System
0 ~ 150 kV ; 60 ~ 400Hz

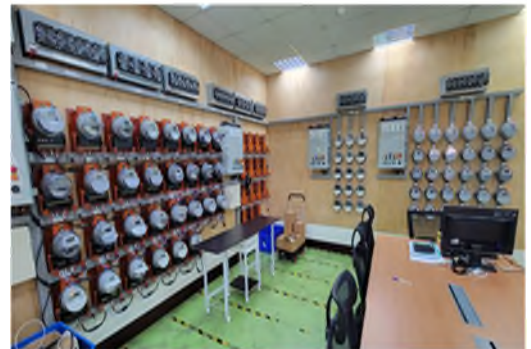

電表與通訊模組交互可用性測試
Operability Testing between Electric Meters
and Communication Modules



電度表修校自動化設備
Watt-hour Meter Repair Automation Equipment

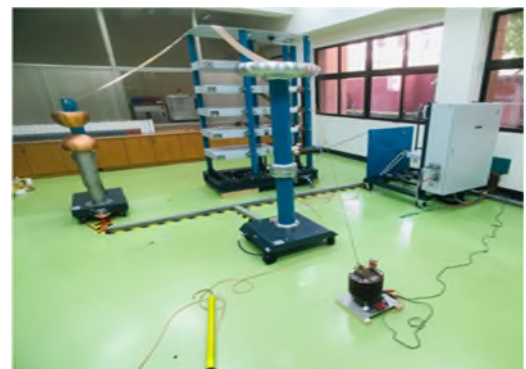

衝擊電壓試驗設備
Impulse Voltage Testing

⚡ 高壓試驗組 High Voltage Testing Section

• 主要試驗內容 Major Test Items

- 345kV 電力電纜/GIS 現場交流耐電壓試驗
On-site AC Withstand Voltage Test up to 345 kV Power Cables/GIS
- 電力電纜部分放電量測(線上)
Partial Discharge Measurement on Power Cable (Online)
- 高壓熔絲試驗
Fuse Test
- 變壓器驗收試驗
Acceptance Test on Taipower Transformer
- 配電級與輸電級避雷器試驗
Distribution and Transmission Lightning Arrester Test
- 短路試驗
Short Circuit Test
- 電力品質量測
Measurement of Power Quality

• 獲得的認證與資格 Accreditation and Qualification

- ISO 17025 高壓測試實驗室(證書號 L0160-231023) : 6 種電力器材試驗認可
ISO 17025 High Voltage Testing Lab(Certificate number : L0160-231023) : 6 Electric Equipment
- ISO 17025 高電壓校正實驗室(證書號 L4377-260109) : 交流 10kV ~ 300kV
ISO 17025 High Voltage Calibration Lab(Certificate number : L4377-260109) : AC 10kV ~ 300kV
- ISO 17020 檢驗機構(證書號 I0018-251117)
ISO 17020 Inspection Body(Certificate number : I0018-251117)
- 經濟部能源署認可高壓用電設備檢驗機構(證書號 : 1043007690-5)
“Inspection Body for High Voltage Equipment” Approved by Energy Administration, Ministry of Economic Affairs (Certificate number :1043007690-5)



電力電纜交流耐電壓試驗
AC Withstand Voltage Test on
Power Cables



大容量短路試驗室
Large Capacity Short Circuit Lab



高電壓校正實驗室
High-volt Calibration Lab

⚡ 化檢組 Chemical Testing Section

• 主要試驗內容 Major Test Items

- 電力系統各類物料 - 金屬、木材、塑膠及橡膠之製品等之化學成分與物理特性試驗
Chemical and Physical Test for Materials of Electrical Power System - Metal, Wood, Plastic and Rubber
- 各類水質及水處理材料特性分析
Water and Water Treatment Materials Properties Analysis
- 事業廢棄物溶出毒性試驗
TCLP Testing for Industrial Waste
- 固體廢棄物、毒性化學物質及相關之環境污染物分析檢驗
Analysis of Solid Wastes、Toxic Chemicals and Related Environmental Pollutants
- 金屬及工程材料機械特性檢驗
Mechanical Property Test for Metal and Engineering Material
- 電力器材金相及破損分析
Metallographic and Fracture Analysis of Boiler and Related Steam-power-plant Equipment

• 獲得的認證與資格 Accreditation and Qualification that We Got

- ISO/IEC 17025 : 2017 ; CNS 17025 : 2018
 - 材料實驗室(TAF 證書編號 : L1883-221223)
Material Laboratory(TAF Accreditation Number : L1883-221223)
 - 環境檢驗室(TAF 證書編號 : L4298-250630)
Environmental Testing Laboratory(TAF Accreditation Number : L4298-250630)

• 主要試驗設備 Major Facility

- 光譜分析儀 - 材料、環境樣品成分分析
Spectroscopy - for Analysis of Chemical Composition of Material and Environmental Samples
- 感應耦合電漿質譜儀-微量元素分析
Inductively Coupled Plasma Mass Spectrometry - for Trace Elements Analysis
- 氣相層析儀 - 物質定性定量分析
Gas Chromatograph - for Qualitative and Quantitative Analysis of Material
- 汞分析儀 - 用於測定固體、液體和氣體基質中的總汞含量
Mercury Analyzer - for Determining total mercury in Solid, Liquid and Gaseous matrices.
- 掃描式電子顯微鏡-金屬與非金屬材料微區顯微組織觀察，適用於電力器材之破損分析
Scanning Electron Microscopy -Microstructure Observation of Metal and non-Metal Materials for Failure Analysis of Electrical Equipment

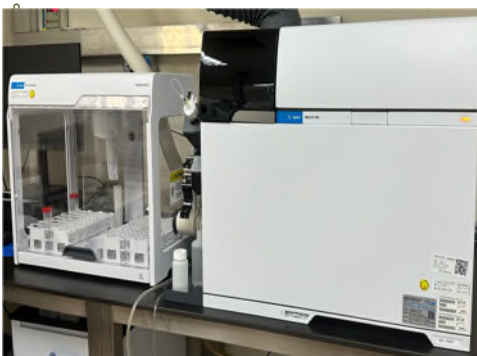

感應耦合電漿質譜儀
ICP-MS

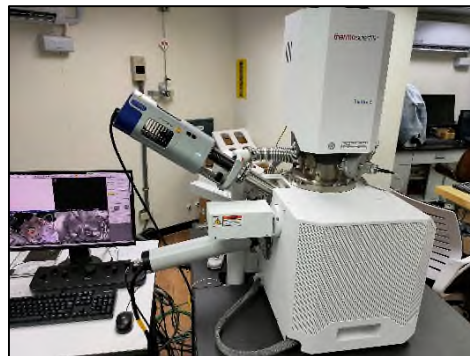

掃描式電子顯微鏡
Scanning Electron Microscopy

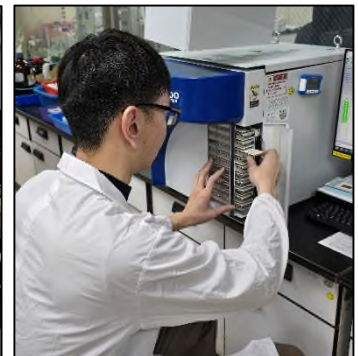

汞分析儀
Mercury Analyzer

油煤試驗組 Oil & Coal Testing Section

• 主要試驗內容 Major Test Items

- 煤、重油、柴油、天然氣等燃料之檢驗分析
Analysis of Coal, Fuel Oil, Natural Gas, etc.
- 絕緣油、潤滑油、液壓油、油膏等油品之檢驗分析
Analysis of Insulating Oil, Lubricants, Hydraulic Fluid, Grease, etc.
- 電力設備用氣體試驗、氣體偵測設備校驗與絕緣油中氣體分析
Analysis of Gas and Dissolved Gas-in-oil and Calibration of Gas Detectors for Electrical Power Equipment

• 應用技術 Applications

- 新製電力變壓器內部製造瑕疵診斷
Manufacturing Defect Diagnosis for New Power Transformer by DGA during Factory Tests
- 運轉中電力變壓器故障預防診斷
Fault Prevention Diagnosis for In-Service Power Transformer
- 事故變壓器故障位置預測
Fault Location Prediction for Failure Transformer
- 充油電纜接續匣故障預防診斷
Fault Prevention Diagnosis for Oil-filled Cable Joint
- 變壓器老化趨勢評估
Aging Tendency Evaluation of Power Transformer
- 氣體斷路器故障預防診斷
Fault Prevention Diagnosis for In-service Gas Insulating Switchgear

• 試驗應用技術 Testing Applications

- 燃料、油料與氣體試驗與採樣諮商服務
Consulting Services for Testing and Sampling of Fuel, Oil and Gas
- 機械設備潤滑油監測分析與磨潤故障偵測
Lubricating Oil Monitoring and Tribological Failure Detection
- 微量水分(0.3ppmv~1%)標準氣體之生產與氣體水分儀校驗
Calibration of Hygrometer and Production of Standard Gas from - 80°C to 10°C Dew Point
- 電力設備中受污染 SF₆ 再生純化處理
Contaminated SF₆ Gas Recycling and Reclamation for Power Facilities



煤炭工業分析
Proximate Analysis of Coal

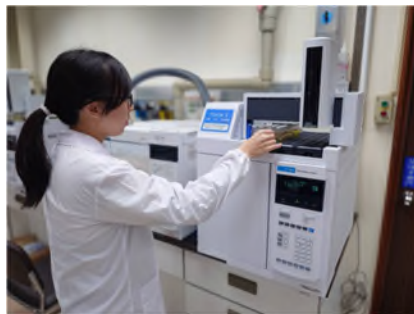

變壓器油中氣體分析
Dissolved Gas Analysis of
Transformer Oil



絕緣油中糠醛分析
Furanic Compound Analysis of
Transformer Oil

展望

因應再生能源大量併網、全球淨零碳排趨勢及用電型態轉變等多重挑戰，本所將持續以「淨零轉型，研發先行」為核心理念，厚實公司推動低碳與零碳轉型所需之核心知識與策略基礎。

展望未來，本所除持續深耕前瞻技術研究與重點領域創新外，亦將積極整合國內外資源，針對確保穩定供電、智慧電網建置、再生能源利用極大化，以及低碳與零碳轉型（如燃料轉換、負碳排技術等）所需之關鍵技術，積極與國際科研機構建立深度技術交流與合作機制，以確保公司攜手國際邁向淨零排放目標之達成。

Future Outlook

In response to the multiple challenges posed by the large-scale integration of renewable energy, the global momentum toward net-zero carbon emissions, and the rapid evolution of electricity consumption patterns, this Institute will continue to uphold its core principle of "Net-Zero Transition, R&D First," steadily strengthening the knowledge base and strategic foundations essential to the Company's low-carbon and zero-carbon transition.

Looking ahead, the Institute will not only deepen its research into frontier technologies and drive innovation across key R&D domains, but will also actively mobilize domestic and international resources to address the critical technologies required for reliable power supply assurance, smart grid development, maximum utilization of renewable energy, and low-carbon and zero-carbon transition — encompassing areas such as fuel switching and negative emissions technologies. Through the establishment of robust mechanisms for in-depth technical exchange and collaboration with leading international research institutions, the Institute is committed to ensuring that the Company advances in concert with the global community toward the realization of net-zero emissions.



台灣電力公司綜合研究所

Taiwan Power Research Institute
Taiwan Power Company

No.198, Sec. 4, Roosevelt Rd., Taipei 100, Taiwan (R.O.C.)

所本部：台北市羅斯福路四段 198 號

TEL: (02) 8369-5758

FAX: (02) 2364-9611

樹林所區：新北市樹林區大安路 84 號

TEL: (02) 2681-5424

FAX: (02) 2682-2793

